

Directional spool valves, pilot-operated, with hydraulic or electro-hydraulic actuation

type WEH and WH



H8051+8052

- ▶ Size 10 ... 32
- ▶ Component series 4X; 6X; 7X
- ▶ Maximum operating pressure 350 bar
- ▶ Maximum flow 1100 l/min

Features

- ▶ 4/3-, 4/2- or 3/2-way version
- ▶ Types of actuation (internal or external pilot control):
 - Electro-hydraulic (type WEH)
 - Hydraulic (type WH)
- ▶ For subplate mounting
- ▶ Porting pattern according to ISO 4401
- ▶ Spring or pressure centering, spring end position or hydraulic end position
- ▶ Wet-pin DC or AC solenoids, optional
- ▶ Electrical connection as individual or central connection
- ▶ Optional versions:
 - Manual override
 - Switching time adjustment
 - Preload valve in channel P of the main valve
 - Stroke setting and/or spool position monitoring

Contents

Features	1
Ordering code	2 ... 4
Symbols	5 ... 9
Function, section	10 ... 12
Pilot oil supply	13 ... 14
Technical data	15 ... 18
Characteristic curves, performance limits	19 ... 28
Dimensions	29 ... 35
Stroke setting, mounting options	36, 37
Switching time adjustment	38
Pressure reducing valve "D3"	38
Preload valve	39
Project planning information	40
Further information	40

Ordering code

01	02	03	04	05	06	07	08	09	10	11	12	13	14	15	16	17	18	19	20	21	22
						/									/						*

01	Up to 280 bar	no code
	Up to 350 bar	H -
02	3-way version	3
	4-way version	4

Types of actuation

03	Electro-hydraulic	WEH
	Hydraulic	WH

Size

04	NG10	10
	NG16	16
	NG25 (version "W.H 22")	22
	NG25 (version "W.H 25")	25
	NG32	32

Control spool return in the main valve

05	By means of springs	no code
	Hydraulic ¹⁾	H
06	For symbols, see page 5 and 6	
07	Component series 40 ... 49 (40 ... 49: unchanged installation and connection dimension) – NG10	4X
	Component series 60 ... 69 (60 ... 69: unchanged installation and connection dimension) – NG25 ("W.H 25") and NG32	6X
	Component series 70...79 (70...79: unchanged installation and connection dimensions) – NG16 (from series 72) and NG25 ("W.H 22")	7X

Control spool return in the pilot control valve with 2 spool positions and 2 solenoids

(Only possible with symbols A, B, C, D, K, Z and hydraulic control spool return in the main valve)

08	With spring return	no code
	Without spring return	O
	Without spring return with detent ²⁾	OF

Pilot control valve ⁽²⁾

09	High-power valve (data sheet 23178)	6E
10	Direct voltage 24 V ²⁾	G24
	Alternating voltage 230 V 50/60 Hz ²⁾	W230
	For other voltages, frequencies and electric data, see data sheet 23178	
11	Without manual override	no code
	With manual override	N
	With concealed manual override	N9

Corrosion resistance (outside)

12	None (valve housing primed)	no code
	Improved corrosion protection (240 h salt spray test according to EN ISO 9227)	J3

Ordering code

01	02	03	04	05	06	07	08	09	10	11	12	13	14	15	16	17	18	19	20	21	22
						/									/						*

Pilot oil flow

13	External pilot oil supply, external pilot oil return ³⁾	no code
	Internal pilot oil supply, external pilot oil return ^{3; 4)}	E
	Internal pilot oil supply, internal pilot oil return ⁴⁾	ET
	External pilot oil supply, internal pilot oil return ³⁾	T
(for type WH... only "no code" ; Version "ET" and "T" with 3-spool position valve, pressure-centered only possible if $p_{St} \geq 2 \times p_{tank} + p_{St\ min}$)		

Switching time adjustment

14	Without switching time adjustment	no code
	Switching time adjustment as supply control	S
	Switching time adjustment as discharge control	S2

Electrical connection ²⁾

15	Individual connection	
	Without mating connector; connector DIN EN 175301-803	K4 ⁵⁾
For further electrical connections, see data sheet 23178 and 08010		

Spool position monitoring

16	Without position switch	no code
	Monitored spool position "a"	QMAG24
	Monitored spool position "b"	QMBG24
	Monitored spool position "a" and "b"	QMABG24
	Monitored rest position	QM0G24
For more information, see data sheet 24830		

Stroke setting

17	For ordering code, see page 35 and 36	
----	---------------------------------------	--

Throttle insert ²⁾

18	Without throttle insert	no code
	Throttle Ø 0.8 mm	B08
	Throttle Ø 1.0 mm	B10
	Throttle Ø 1.2 mm	B12
	Throttle Ø 1.5 mm	B15
	Throttle Ø 2.0 mm	B20
	Throttle Ø 2.5 mm	B25

p_{St} = pilot pressure

$p_{St\ min}$ = minimum pilot pressure

p_{Tank} = tank pressure

p_{δ} = cracking pressure

Ordering code

01	02	03	04	05	06	07	08	09	10	11	12	13	14	15	16	17	18	19	20	21	22	
						/									/							*

Preload valve (not for NG10) ²⁾

19	Without preload valve	no code
	With preload valve ($p_o = 4.5$ bar)	P4,5
20	Without pressure reducing valve	no code
	With pressure reducing valve	D3 ⁶⁾

Seal material (observe compatibility of seals with hydraulic fluid used, see page 17)

21	NBR seals	no code
	FKM seals	V
	Recommended for operation with HFC hydraulic fluids together with high temperatures	MH
	Low-temperature version (only with version "Without manual override")	MT
22	For further information, see the plain text	*

- 1) ▶ 2 switching positions (hydraulic end position): only symbols C, D, K, Z, Y
 ▶ 3 switching positions (hydraulically centered): only NG16, NG25 ("4W.H 25") and NG32
- 2) With electro-hydraulic actuation only (type WEH)
- 3) Pilot oil supply X or return Y **external**:
- ▶ The maximum admissible operating parameters of the pilot control valve must be observed (see data sheet 23178).
 - ▶ Minimum pilot pressure: please observe page 16.
 - ▶ Maximum pilot pressure: please observe page 16.
- 4) Pilot oil supply **internal** (version "ET" and "E"):
- ▶ Minimum pilot pressure: please observe page 16.
 - ▶ Maximum pilot pressure: please observe page 16. With a higher pilot pressure, use of a **pressure reducing valve "D3"** is required (if it is not used, pilot pressure = operating pressure at the port).
 - ▶ In order to prevent inadmissibly high pressure peaks, a **"B10" throttle insert** has to be provided in port P of the pilot control valve (see page 14).
 - ▶ In connection with version "H", the **pressure reducing valve "D3"** is also required.
- 5) Mating connectors, separate order, see data sheet 23178
- 6) In connection with the **"B10"** throttle insert only

Symbols: 2 spool positions

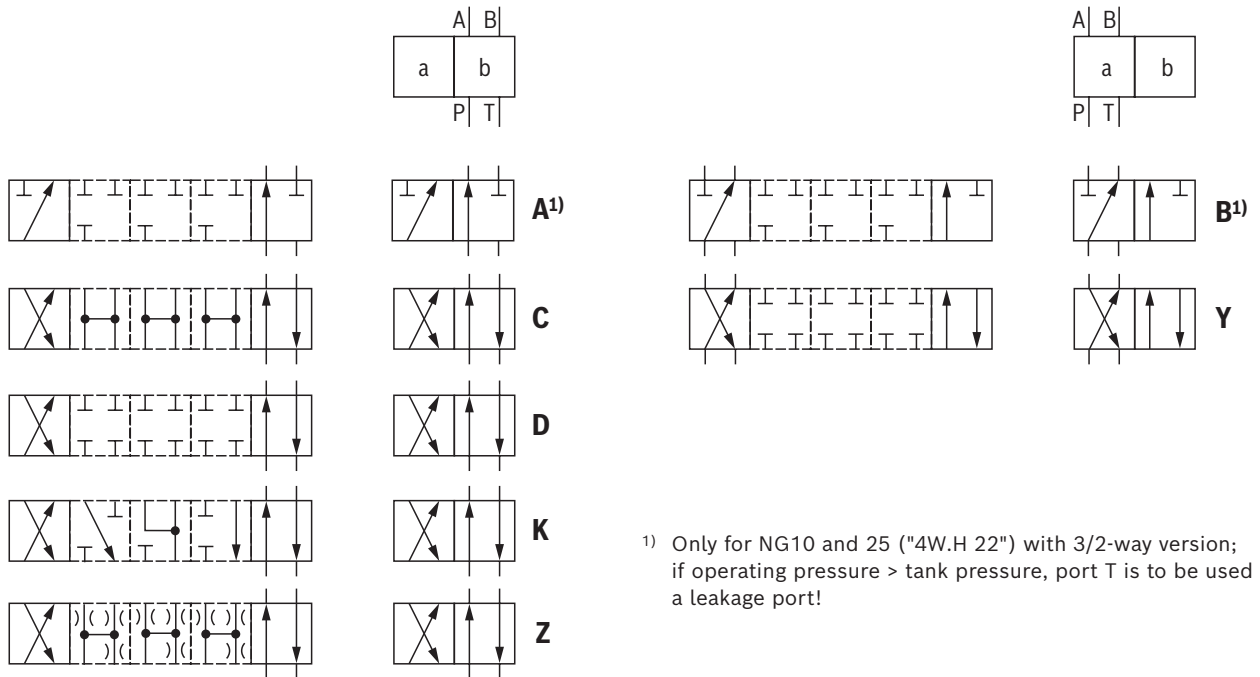

¹⁾ Only for NG10 and 25 ("4W.H 22") with 3/2-way version; if operating pressure > tank pressure, port T is to be used as a leakage port!

Ordering code		Type of actuation	
Symbol	Control spool return	Type WH (hydraulic)	Type WEH (electro-hydraulic)
A ¹⁾ , C, D, K, Z	../..		
	..H../..		
	..H../O		
	..H../OF		
B ¹⁾ , Y	../..		
	..H../..		

Symbols: 3 spool positions

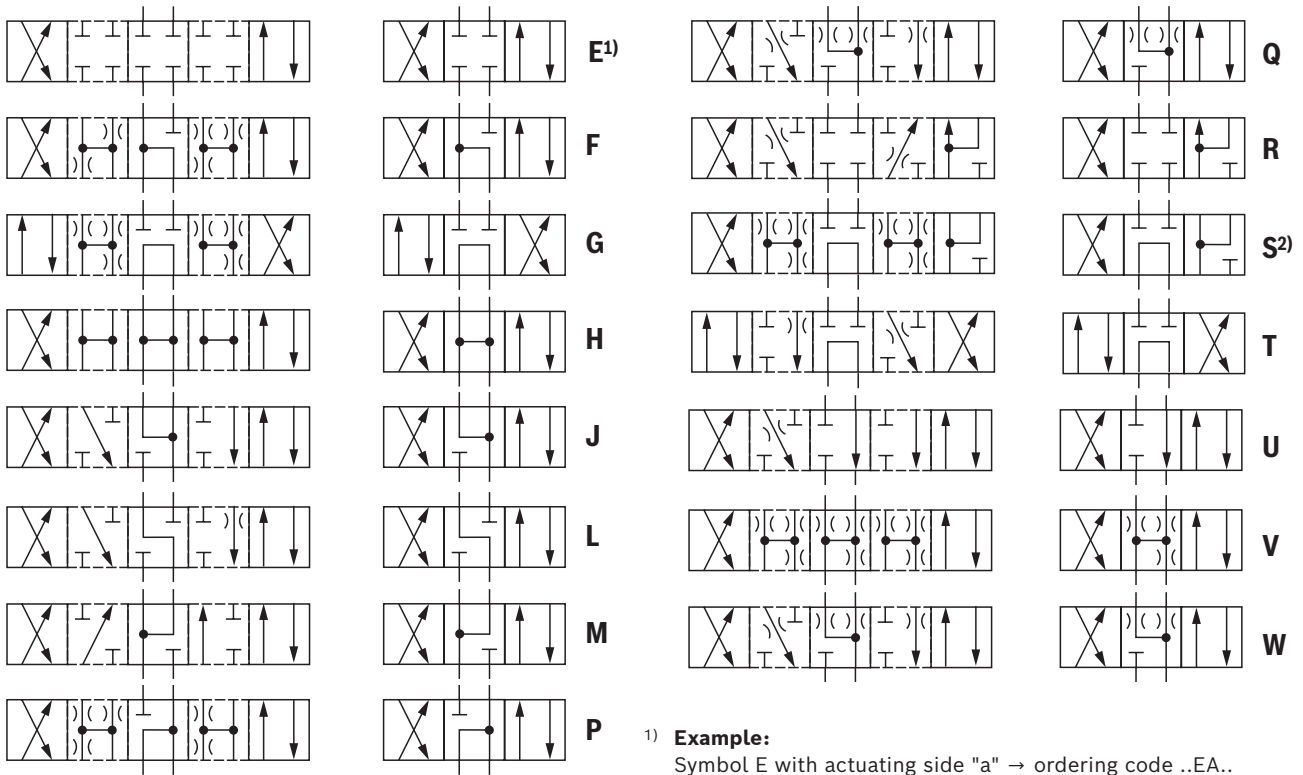

- 1) **Example:**
Symbol E with actuating side "a" → ordering code ..EA..
- 2) Symbol S only for NG16

Symbol	Ordering code		Type of actuation		
	Actuating side	Control spool return	Type WH (hydraulic)	Type WEH (electro-hydraulic)	
E, F, G, H, J, L, M, P, Q, R, S, T, U, V, W		../..			
	.A				
	.B				
		..H../..			
		H.A			
		H.B			

Symbols for valves with 2 spool positions

	Valve with spring end position	Valve with hydraulic end position		
X = external; Y = external	Type WEH.../.. 	Type WEH . H../... 	Type WEH . H../O... 	Type WEH . H../OF...
	Type WEH.../...E... 	Type WEH . H../...E... 	Type WEH . H../O...E... 	Type WEH . H../OF...E...
	Type WEH.../...ET... 	Type WEH . H../...ET... 	Type WEH . H../O...ET... 	Type WEH . H../OF...ET...

Symbols for valves with 2 spool positions

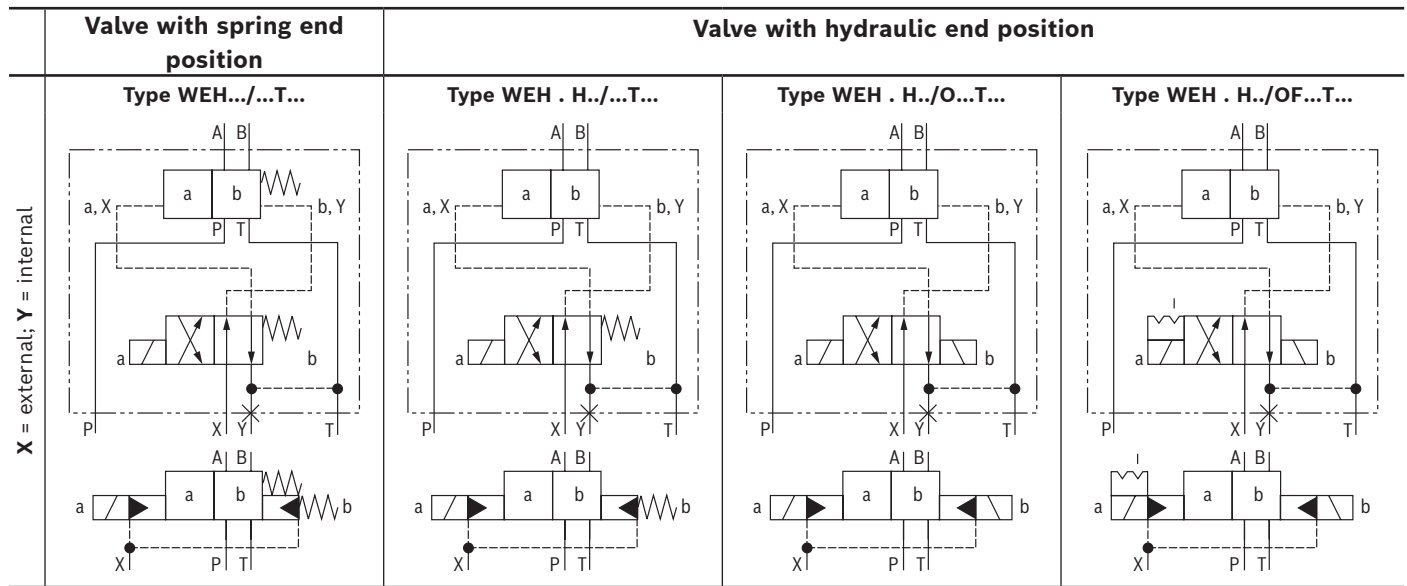

Symbols for valves with 3 spool positions

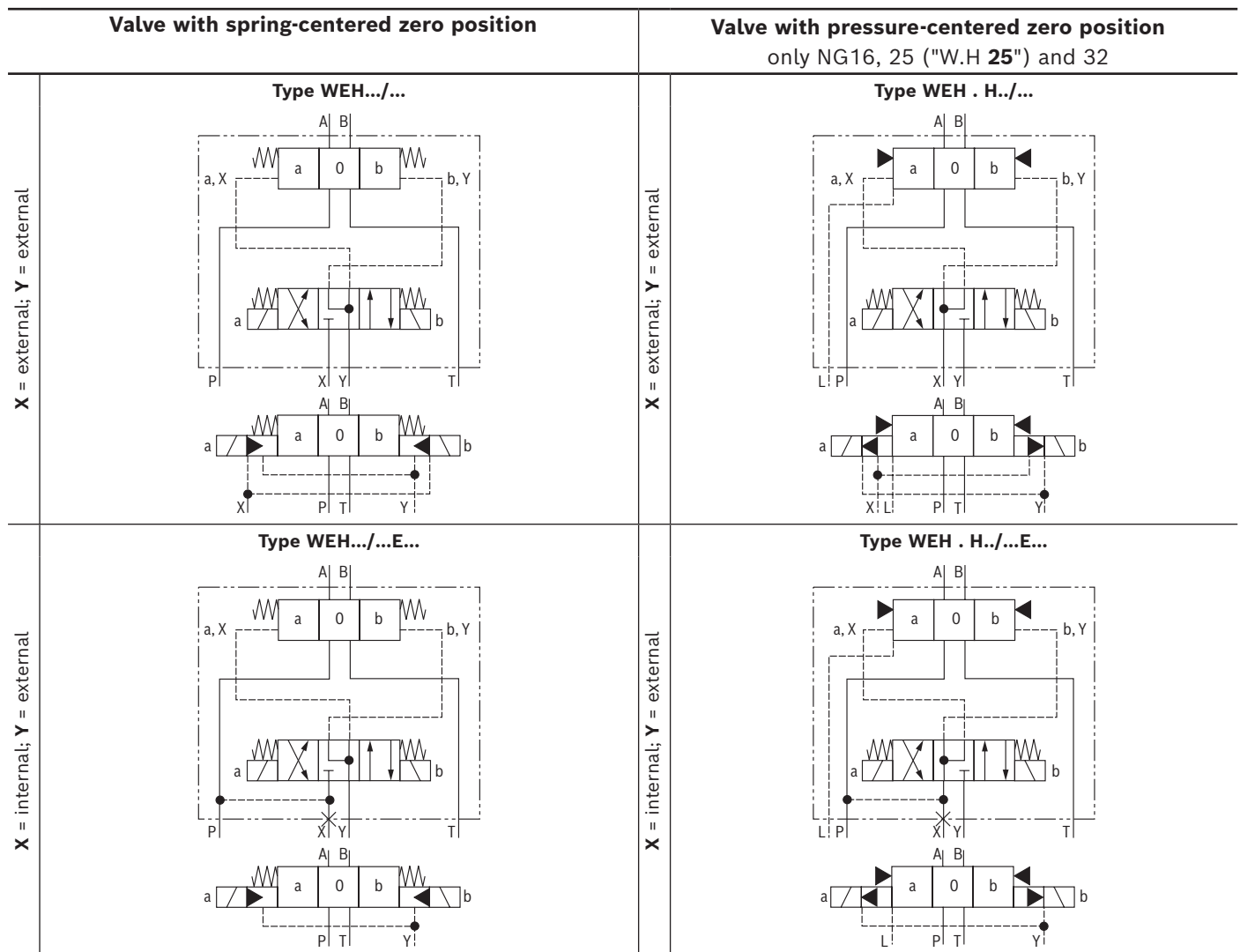

Symbols for valves with 3 spool positions

Valve with spring-centered zero position		Valve with pressure-centered zero position only NG16, 25 ("W.H 25") and 32	
X = internal; Y = internal	<p style="text-align: center;">Type WEH.../...ET...</p>	X = external; Y = external	<p style="text-align: center;">Type WEH . H../...ET...</p>
X = external; Y = internal	<p style="text-align: center;">Type WEH.../...T...</p>	X = internal; Y = external	<p style="text-align: center;">Type WEH . H../...T...</p>

Notice:

3-spool position valves, pressure-centered, preferably with external pilot oil supply and/or return ("no code", "E")
For preconditions for internal pilot oil supply and/or return ("ET", "T"), see page 4 and 15.

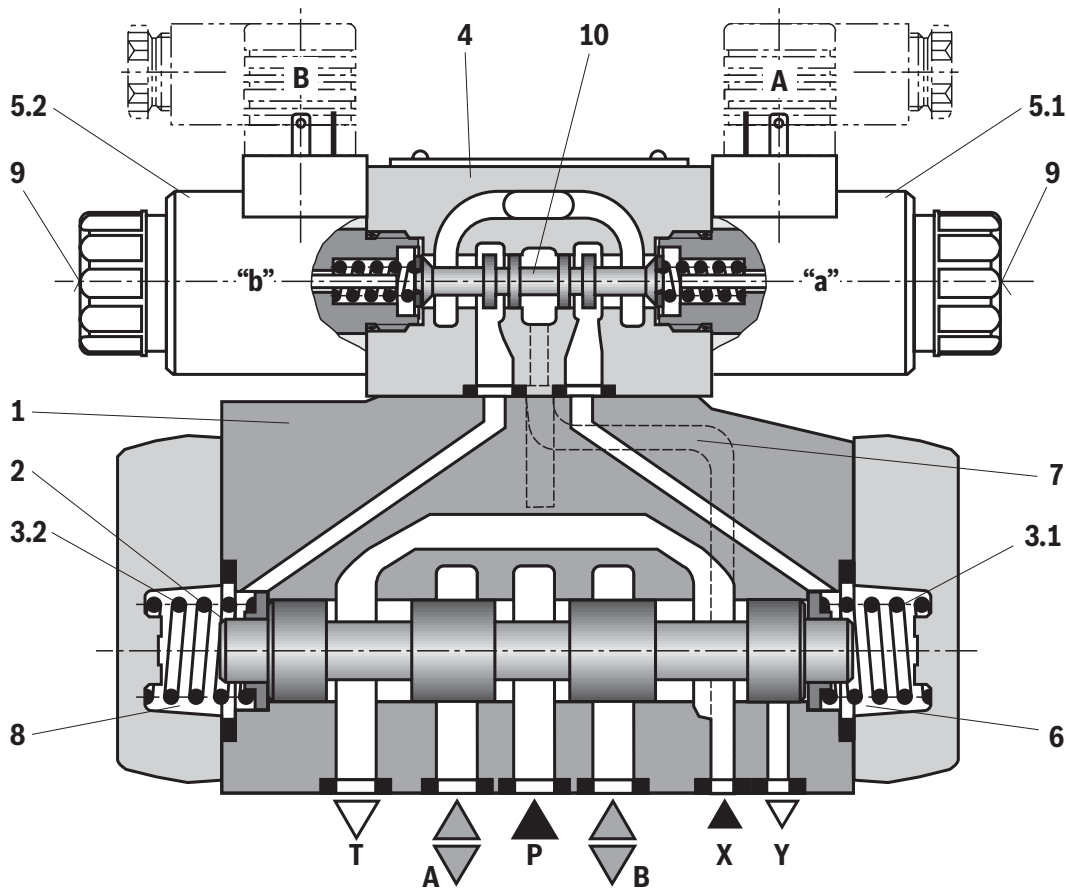
Function, section: Type WEH**Directional valves type WEH...**

The valve type WEH is a directional spool valve with electro-hydraulic actuation. It controls the start, stop and direction of a flow.

The directional valves basically consist of the main valve with housing (1), the main control spool (2), one or two return springs (3.1) and (3.2), as well as the pilot control valve (4) with one or two solenoids "a" (5.1) and/or "b" (5.2).

For unobjectionable functioning, the hydraulic system has to be bled properly.

For valves with three spool positions, the main control spool (2) in the main valve is held in zero position or initial position by means of two springs, for valves with 2 spool positions by pressurization and spring. In the initial position, the two spring chambers (6) and (8) are connected with the tank in a depressurized form via the pilot control valve (4). Via the control line (7), the pilot control valve is supplied with pilot oil. Supply can be implemented internally or externally (externally via port X). Upon actuation of the pilot control valve, e.g. solenoid "a", the pilot control spool (10) is moved to the left and thus, the spring chamber (8) is pressurized with pilot pressure. The spring chamber (6) remains depressurized.

The pilot pressure acts on the left side of the main control spool (2) and moves it against the spring (3.1). This connects port P with B and A with T in the main valve. On switching off of solenoid, the pilot control spool (10) returns to its initial position (except impulse spool). The spring chamber (8) is unloaded to the tank. The pilot oil return is implemented internally (via channel T) or externally (via channel Y). An optional manual override (9) allows for moving of the pilot control spool (10) without solenoid energization.

Notices:

The return springs (3.1) and (3.2) in the spring chambers (6) and (8) hold the main control spool (2) in central position without pilot pressure even with, for example, vertical valve positioning.

Due to the design principle, internal leakage is inherent to the valves, which may increase over the life cycle.

For pilot oil supply, see page 13 and 14.

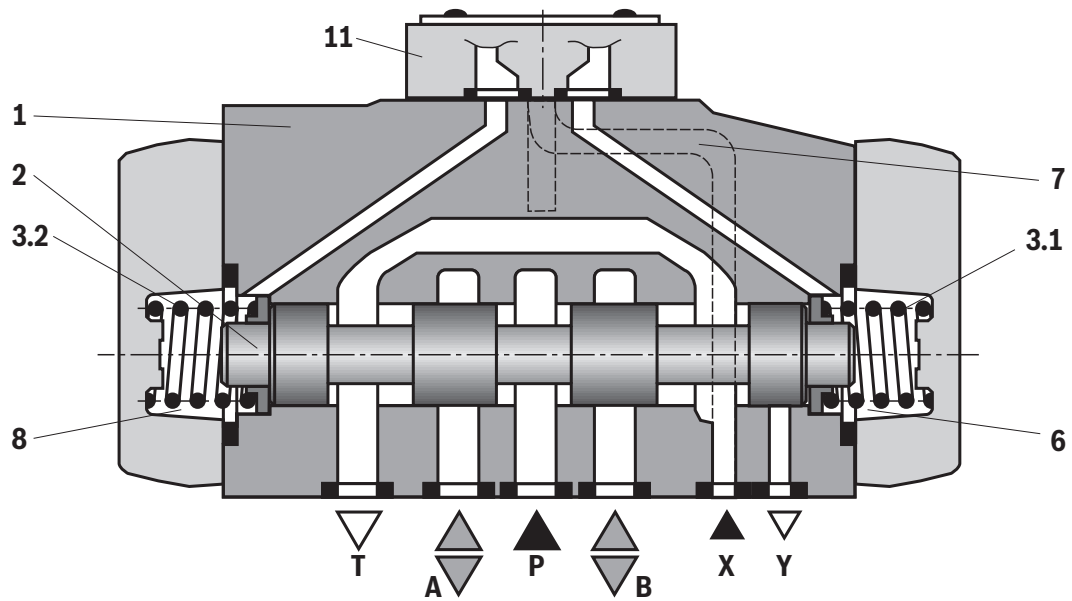
Function, section: Type WH**Directional valves type WH...**

Valve type WH is a directional spool valve with hydraulic actuation. It controls the start, stop and direction of a flow.

The directional valve basically consists of the valve housing (1), the main control spool (2), one or two return springs (3.1) and (3.2) at valves with spring return or spring centering as well as the diversion plate (11).

The main control spool (2) is actuated directly by pressurization.

The main control spool (2) is held in zero or initial position by springs or pressurization. Pilot oil supply and return are external (see page 13).

4/3 directional valve with spring centering of the control spool

With this version, the main control spool (2) is held in zero position by two return springs (3.1) and (3.2). Via the diversion plate (11), the spring chamber (6) is connected to port Y, the spring chamber (8) to port X.

With pilot pressure loading of one of the two front sides of the main control spool (2), the spool is moved to the spool position. In the valve, the required ports are connected in this way.

The spring on the opposite side returns the spool to the zero or initial position at pressure relief of the pressurized control spool area.

For pilot oil supply, see page 13 and 14.

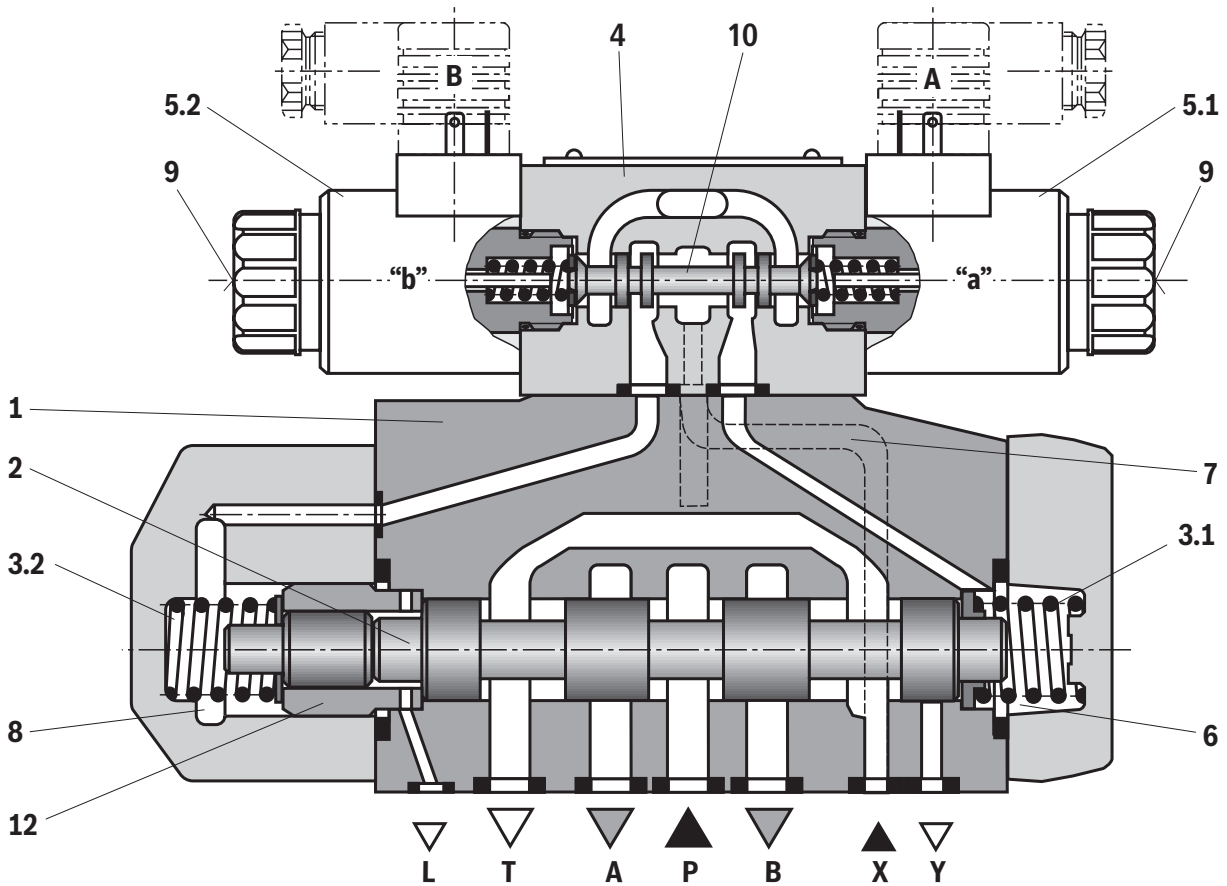
Function, section: Type WEH...H**4/3 directional valve with pressure centering of the main control spool, type WEH...H**

The main control spool (2) in the main valve is kept in the zero position by pressurization of the two front faces.

One centering bush (12) rests on the housing and fixes the control spool position.

By pressure relief of one front face, the main control spool (2) is moved to the spool position.

The unloaded control spool face displaces the returning pilot oil into channel Y (external) via the pilot control valve.

Notices:

The springs (3.1) and (3.2) do not have a return function in this version. They hold the main control spool (2) in central position in the depressurized condition and with horizontal installation.

Pilot oil supply (schematic illustration)

NG10

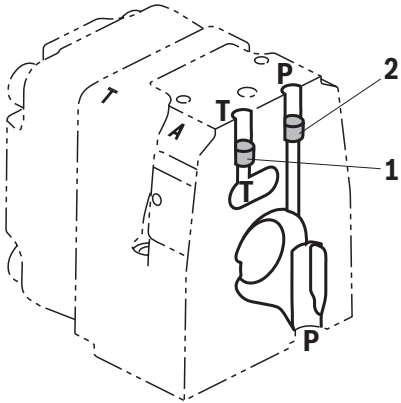

NG16

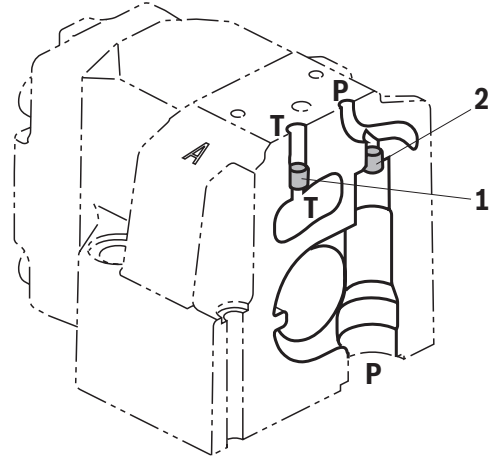

NG25 ("W.H 22")

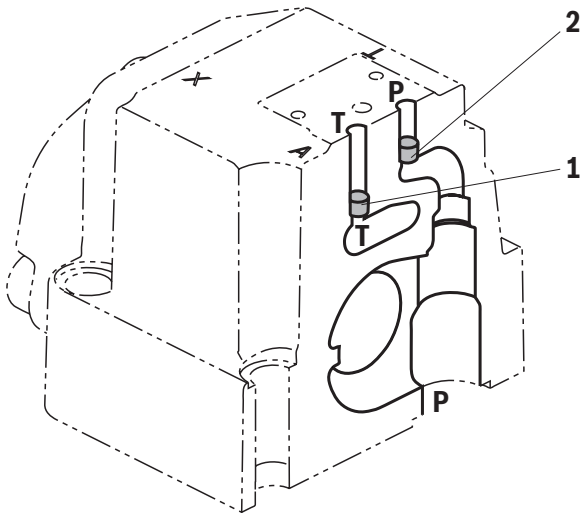

NG25 ("W.H 25")

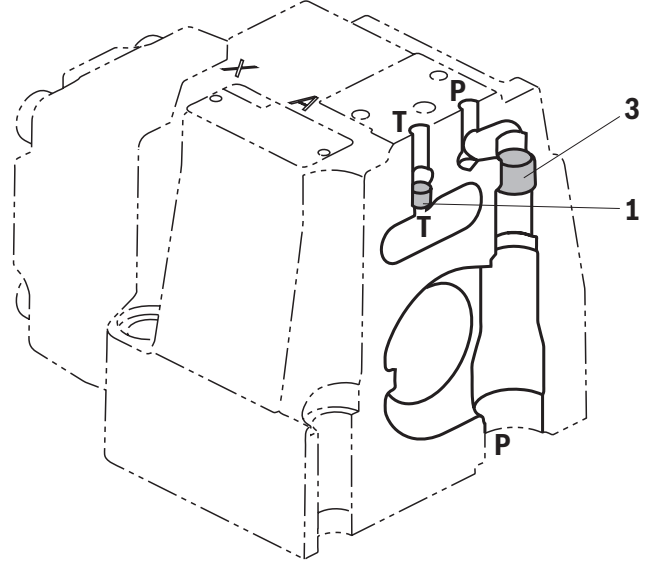

NG32

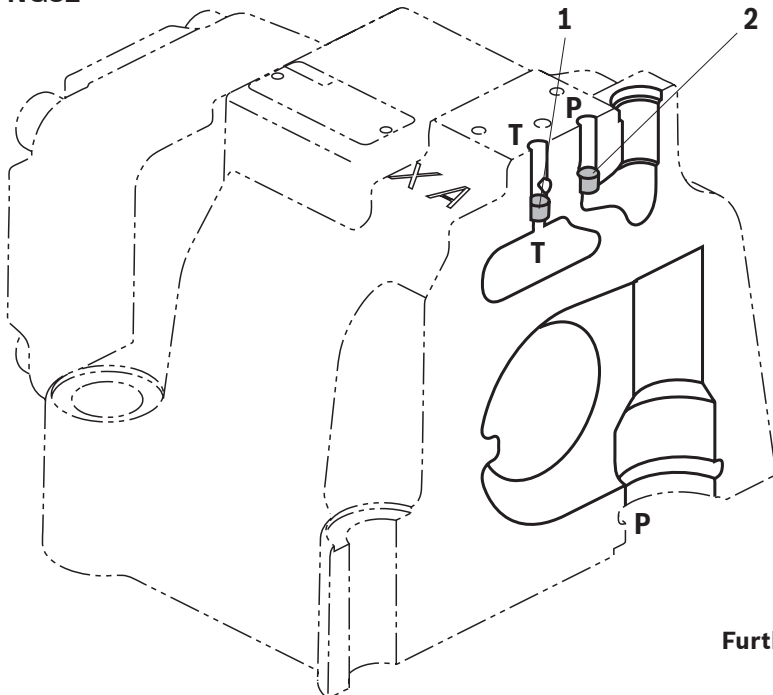

- 1** Plug screw M6 according to DIN 906, wrench size 3 – pilot oil return
- 2** Plug screw M6 according to DIN 906, wrench size 3 – pilot oil supply
- 3** Plug screw M12 x 1.5 according DIN 906, wrench size 6 – pilot oil supply

Pilot oil supply

external: **2, 3** closed
 internal: **2, 3** open

Pilot oil return

external: **1** closed
 internal: **1** open

Further explanations on page 14.

Pilot oil supply

Type WH...

The pilot oil supply and return is implemented **externally** via channel X and Y.

Type WEH...

The pilot oil supply is implemented **externally** - via channel X - from a separate pressure supply.

The pilot oil return is implemented **externally** - via channel Y - into the tank.

Type WEH...E...

The pilot oil supply is implemented **internally** from channel P of the main valve. (see page 15, footnotes ⁵⁾ and ⁶⁾)

The pilot oil return is implemented **externally** - via channel Y - into the tank. In the subplate, port X is closed.

Type WEH...ET...

The pilot oil supply is implemented **internally** from channel P of the main valve.

The pilot oil return is implemented **internally** - via channel T - into the tank. In the subplate, ports X and Y are closed.

Type WEH...T...

The pilot oil supply is implemented **externally** - via channel X - from a separate pressure supply.

The pilot oil return is implemented **internally** - via channel T - into the tank. In the subplate, port Y is closed.

Throttle insert

Use of the throttle insert (5) is necessary if the pilot oil supply in channel P of the pilot control valve is to be limited (see below).

The throttle insert (5) is inserted in channel P of the pilot control valve.

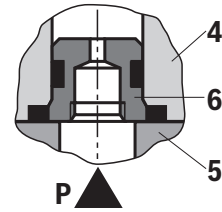

Notices:

The modification of the pilot oil supply may only be performed by authorized specialists or at the factory.

- ▶ Pilot oil supply X or return Y **external**:
 - The maximum admissible operating parameters of the pilot control valve must be observed (see data sheet 23178).
 - Maximum pilot pressure: please observe page 16.
- ▶ Pilot oil supply **internal** (version "ET" and "E"):
 - Minimum pilot pressure: please observe page 15.
 - In order to prevent inadmissibly high pressure peaks, a **"B10" throttle insert** has to be provided in port P of the pilot control valve (see above).
 - In connection with version "H", the **pressure reducing valve "D3"** (see page 37) is also required.

- 3 Pilot control valve
- 4 Main valve
- 5 Throttle insert

Technical data

(For applications outside these values, please consult us!)

General							
Sizes	NG		10	16	25 "W.H 22"	25 "W.H 25"	32
Weight, approx.	▶ Valve with one solenoid	kg	6.4	8.5	11.5	17.6	17.6
	▶ Valve with two solenoids, spring-centered	kg	6.8	8.9	11.9	19.0	41.0
	▶ Valve with two solenoids, pressure-centered	kg	6.8	8.9	11.9	19.0	41.0
	▶ Valve with hydraulic actuation (type WH...)	kg	5.5	7.3	10.5	16.5	39.5
	▶ Switching time adjustment "S" and "S2"	kg	0.8	0.8	0.8	0.8	0.8
	▶ Pressure reducing valve "D3"	kg	0.4	0.4	0.4	0.4	0.4
Installation position	With suspended installation, higher sensitivity to contamination, horizontal is recommended. For valves with hydraulic control spool return "H" and symbol C, D, K, Z, Y, horizontal is required.						
Ambient temperature range	▶ Standard version	°C	-20 ... +50 (NBR seals) -15 ... +50 (FKM seals)				
	▶ Version for HFC hydraulic fluid	°C	-20 ... +50				
Storage temperature range		°C	+5 ... +40				
Surface protection (valve body)	Coating, layer thickness max. 100 µm						
MTTF _d values according to EN ISO 13849		years	100 (type WEH), 150 (type WH) (For further details, see data sheet 08012)				

Hydraulic								
Maximum operating pressure								
▶ Port P, A, B	Type W.H	bar	280	280	280	280	280	
	Type H-W.H	bar	350	350	350	350	350	
▶ Port T	Pilot oil return Y external	Type W.H	bar	280	250	250	250	250
		Type H-W.H		315	250	250	250	250
	Pilot oil return Y internal ¹⁾	Type H-WEH, WEH	bar	210 with DC voltage 160 with AC voltage				
▶ Port Y	Pilot oil return external	Type H-WEH, WEH	bar	210 with DC voltage 160 with AC voltage				
		Type WH, H-WH	bar	250	250	210	250	250
Hydraulic fluid	see table page 17							
Hydraulic fluid temperature range (at the valve working ports) ³⁾		°C	-20 ... +80 (NBR seals) -15 ... +80 (FKM seals) -20 ... +50 (HFC hydraulic fluid)					
Viscosity range		mm ² /s	2.8 ... 500					
Maximum admissible degree of contamination of the hydraulic fluid, cleanliness class according to ISO 4406 (c)	Class 20/18/15 ²⁾							

¹⁾ As a 3-spool position valve, pressure-centered only possible if

$$p_{St} \geq 2 \times p_{tank} + p_{St \text{ min.}}$$

²⁾ The cleanliness classes specified for the components must be adhered to in hydraulic systems. Effective filtration prevents faults and simultaneously increases the life cycle of the components.

For selecting the filters, see www.boschrexroth.com/filter.

³⁾ If type WH is used in potentially explosion-proof areas, see data sheet 07011.

Technical data

(For applications outside these values, please consult us!)

Hydraulic							
Size	NG	10	16	25 "W.H 22"	25 "W.H 25"	32	
Maximum pilot pressure ⁴⁾	bar	250	250	210	250	250	
Minimum pilot pressure							
▶ Pilot oil supply X external (all symbols), Pilot oil supply X internal (only symbols D, K, E, J, L, M, Q, R, U, W)							
3-spool position valve, spring-centered	Type H-W.H... Type W.H...	bar	12 12	14 14	12.5 10.5	13 13	8.5 8.5
3-spool position valve, pressure-centered		bar	-	16	-	18	8.5
2-spool position valve with spring end position	Type H-W.H... Type W.H...	bar	10 10	14 14	14 11	13 13	10 10
2-spool position valve with hydraulic end position		bar	7	14	8	8	5
▶ Pilot oil supply X internal (only type WEH) (with symbols C, F, G, H, P, T, V, Z, S ⁵⁾)		bar	7.5 ⁶⁾	4.5 ⁷⁾	4.5 ⁷⁾	4.5 ⁷⁾	4.5 ⁷⁾
Free flow cross-sections in zero position with symbols Q, V and W							
▶ Symbol Q	A - T; B - T	mm ²	13	32	78	83	78
▶ Symbol V	P - A; P - B A - T; B - T	mm ²	13 13	32 32	73 84	83 83	73 84
▶ Symbol W	A - T; B - T	mm ²	2.4	6	10	14	20
Pilot volume for switching process							
▶ 3-spool position valve, spring-centered		cm ³	2.04	5.72	7.64	14.2	29.4
▶ 2-spool position valve		cm ³	4.08	11.45	15.28	28.4	58.8
▶ 3-spool position valve, pressure-centered							
from zero position in switching position "a"	Type WH Type WEH	cm ³	- -	2.83 2.83	- -	7.15 7.15	14.4 14.4
from switching position "a" in zero position	Type WH Type WEH	cm ³	- -	5.72 2.9	- -	14.18 7.0	29.4 15.1
from zero position in switching position "b"	Type WH Type WEH	cm ³	- -	5.72 5.72	- -	14.18 14.15	29.4 29.4
from switching position "b" in zero position	Type WH Type WEH	cm ³	- -	8.55 2.83	- -	19.88 5.73	43.8 14.4
Pilot flow for shortest switching time, approx.		l/min	35	35	35	35	45

Technical data

(For applications outside these values, please consult us!)

Hydraulic fluid	Classification	Suitable sealing materials	Standards	Data sheet
Mineral oils	HL, HLP, HLPD, HVLP, HVLPD	NBR, FKM	DIN 51524	90220
Bio-degradable	▶ Insoluble in water	HETG	ISO 15380	90221
		HEES		
	▶ Soluble in water	HEPG	ISO 15380	
Flame-resistant	▶ Water-free	HFDU (glycol base)	ISO 12922	90222
		HFDU (ester base)		
		HFDR		
	▶ Containing water	HFC (Fuchs: Hydrotherm 46M, Renosafe 500; Petrofer: Ultra Safe 620; Houghton: Safe 620; Union: Carbide HP5046)	ISO 12922	90223



Important notices on hydraulic fluids:

- ▶ For further information and data on the use of other hydraulic fluids, please refer to the data sheets above or contact us.
- ▶ There may be limitations regarding the technical valve data (temperature, pressure range, life cycle, maintenance intervals, etc.).
- ▶ The ignition temperature of the hydraulic fluid used must be 50 K higher than the maximum surface temperature.
- ▶ **Bio-degradable and flame-resistant – containing water:** If this hydraulic fluid is used, small amounts of dissolved zinc may get into the hydraulic system.

▶ Flame-resistant – containing water:

- Due to increased cavitation tendency with HFC hydraulic fluids, the life cycle of the component may be reduced by up to 30% as compared to the use with mineral oil HLP. In order to reduce the cavitation effect, it is recommended - if possible specific to the installation - to back up the return flow pressure in ports T to approx. 20% of the pressure differential at the component.
- Dependent on the hydraulic fluid used, the maximum ambient and hydraulic fluid temperature must not exceed 50 °C. In order to reduce the heat input into the component, a maximum duty cycle of 50% in continuous operation has to be set for on/off valves (measuring period 300 s). If this is impossible due to the function, an energy-reducing control of these components is recommended, e.g. via a PWM plug-in amplifier.

4) ▶ Internal pilot oil supply:

- With a higher pilot pressure, use of a **pressure reducing valve "D3"** is required (if it is not used, pilot pressure = operating pressure at the port).
- In connection with version "H-", the **pressure reducing valve "D3"** is also required.

▶ External pilot oil supply:

- Compliance with the maximum pilot pressure must be ensured by appropriate measures (e.g. protection of the separate pilot oil circuit by using a pressure relief valve).

5) Symbol S only for NG16

6) For symbols C, F, G, H, P, T, V, Z, an internal pilot oil supply is only possible if the flow from P to T in the central position (for 3-spool position valve) or while crossing the central position (for 2-spool position valve) is so large that the pressure differential of P to T reaches a value of at least 7.5 bar.

For a pressure differential below 7.5 bar, a check valve with a cracking pressure of 7.5 bar is to be provided in the return line to the tank. An external pilot oil supply Y is required.

7) Pilot oil supply X internal is only possible for a pressure at P of minimum 4.5 bar.

For symbols with negative overlap F, G, H, P, T, V, (S only NG16), a certain flow from P to T in the central position is necessary for this purpose (see "characteristic curves").

For symbols C, HC, Z, HZ, a flow of >160 l/min is required during passing over the central position for NG16, for NG22, 25 and 32 a flow of >180 l/min.

If the required flows are not reached, a preload valve has to be used. When using a preload valve, the pressure differential of the preload valve of the corresponding size (see page 38) is to be added to the corresponding pressure differential in case of direction of flow P ("see characteristic curves").

Switching times

Pilot pressure		bar	70	210	250	Spring
			ON			OFF
NG10	▶ Without throttle insert	ms	40 ... 60	–	40 ... 60	20 ... 30
	▶ With throttle insert	ms	60 ... 90	–	50 ... 70	20 ... 30
NG16	▶ Without throttle insert	ms	50 ... 80	–	40 ... 60	50 ... 80
	▶ With throttle insert	ms	110 ... 130	–	80 ... 100	50 ... 80
NG25 ("4W.H 22")	▶ Without throttle insert	ms	40 ... 70	40 ... 60	–	50 ... 70
	▶ With throttle insert	ms	140 ... 160	80 ... 110	–	50 ... 70
NG25 ("4W.H 25")	▶ Without throttle insert	ms	70 ... 100	–	50 ... 70	100 ... 130
	▶ With throttle insert	ms	200 ... 250	–	120 ... 150	100 ... 130
NG32	▶ Without throttle insert	ms	80 ... 130	–	70 ... 100	140 ... 160
	▶ With throttle insert	ms	420 ... 560	–	230 ... 350	140 ... 160

Notices:

- ▶ Switching times = Contacting at the pilot control valve until start of opening of the control edge in the main valve and change in the control spool stroke by 95%)
- ▶ The switching times are measured according to ISO 6403 with HLP46, $\vartheta_{oil} = 40 \text{ °C} \pm 5 \text{ °C}$.
With different oil temperatures, variations are possible.
- ▶ The switching times were determined using DC solenoids. They decrease by approx. 20 ms if AC solenoids are used.
- ▶ The shut-off of the solenoids creates voltage peaks, which can be reduced by the use of suitable diodes.
- ▶ The switching times increase by approx. 30 ms if the pressure reducing valve "D3" is used.
- ▶ The switching times were determined under ideal conditions and may differ in the system, depending on the application conditions.

Characteristic curves: NG10
(measured with HLP46, $\vartheta_{oil} = 40 \pm 5 \text{ }^\circ\text{C}$)

Δp - q_V characteristic curves

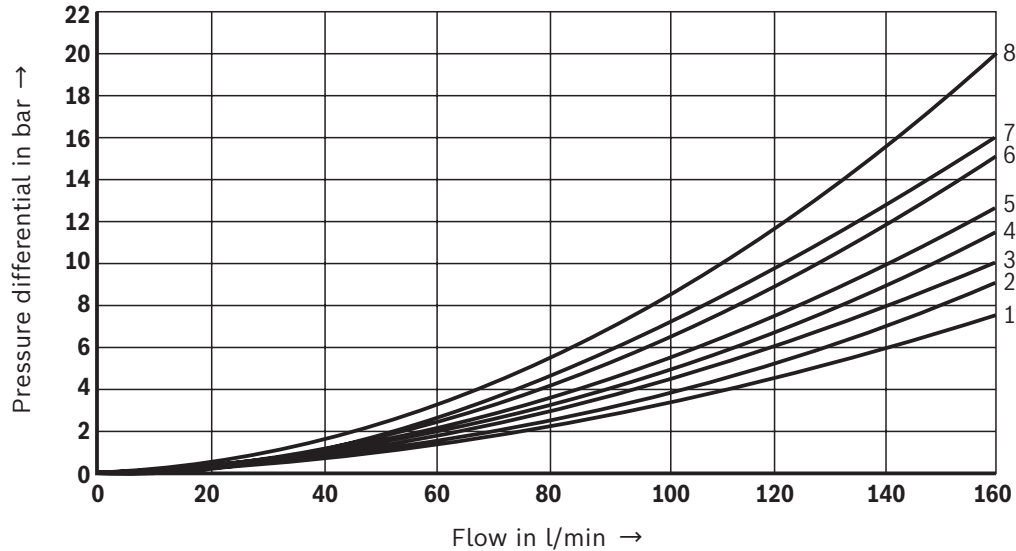

Symbol	Spool position				Zero position		
	P - A	P - B	A - T ¹⁾	B - T ¹⁾	A - T	B - T	P - T
E, Y, D, Q, V, W, Z	1	1	3	5			
F	1	3	1	4	3	-	6
G, T	4	2	4	7	-	-	8
H, C	3	3	1	7	1	5	5
J, K	1	2	1	6			
L	2	2	1	4	2	-	-
M	3	3	2	5			
P	3	1	2	7	-	5	7
R	1	2	3	-			
U	2	2	3	6	-	6	-
A, B	1	1	-	-			

¹⁾ The pressure differential refers to the use of port T. If port T1 is used in addition, the pressure differential may be lower. If only port T1 is used, the relations A - T and B - T may be reversed.

Performance limits: NG10
(measured with HLP46, $\vartheta_{oil} = 40 \pm 5 \text{ }^\circ\text{C}$)

2-spool position valves – $q_{V \max}$ in l/min

Symbol	Operating pressure p_{\max} in bar				
	70	140	210	280	350
X external – spring end position in the main valve¹⁾ (at $p_{St \min} = 12 \text{ bar}$)					
C, D, K, Y, Z	160	160	160	160	160
X external – hydraulic end position in the main valve					
HC, HD, HK, HZ, HY	160	160	160	160	160

3-spool position valves – $q_{V \max}$ in l/min

Symbol	Operating pressure p_{\max} in bar				
	70	140	210	280	350
X external – spring-centered					
E, J, L, M, Q, U, V, W, R	160	160	160	160	160
F, P	160	120	100	90	90
G, T	160	160	160	130	120
H	160	160	120	110	100

¹⁾ If the pilot pressure fails, the function of the return spring is no longer guaranteed with the specified flow values.

For important notices, see page 27.

Characteristic curves: NG16
(measured with HLP46, $\vartheta_{oil} = 40 \pm 5 \text{ }^\circ\text{C}$)

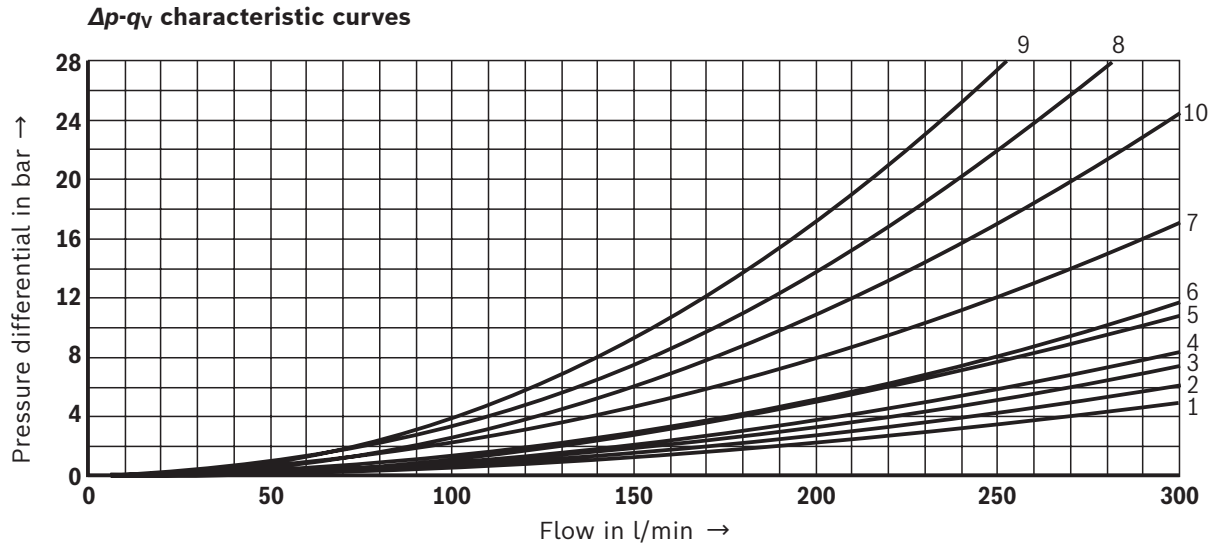

Symbol	Spool position				Zero position		
	P - A	P - B	A - T	B - T	P - T	A - T	B - T
D, E, Y	1	1	3	3			
F	1	2	5	5	4	3	-
G	4	1	5	5	7	-	-
C, H	1	1	5	6	2	4	4
K, J	2	2	6	6	-	3	-
L	2	2	5	4	-	3	-
M	1	1	3	4			
P	2	1	3	6	5	-	-

Symbol	Spool position				Zero position		
	P - A	P - B	A - T	B - T	P - T	A - T	B - T
Q	1	1	6	6			
R	2	4	7	-			
S	3	3	3	-	9	-	-
T	4	1	5	5	7	-	-
U	2	2	3	4			6
V, Z	1	1	6	6	10	8	8
W	1	1	3	4			

Performance limits: NG16
(measured with HLP46, $\vartheta_{oil} = 40 \pm 5 \text{ }^\circ\text{C}$)

2-spool position valves – $q_{V \max}$ in l/min

Symbol	Operating pressure p_{\max} in bar				
	70	140	210	280	350
X external – spring end position in the main valve (at $p_{St \min} = 12 \text{ bar}$)					
C, D, K, Y, Z	300	300	300	300	300
X external – spring end position in the main valve ¹⁾					
C	300	300	300	300	300
D, Y	300	270	260	250	230
K	300	250	240	230	210
Z	300	260	190	180	160
X external – hydraulic end position in the main valve					
HC, HD, HK, HZ, HY	300	300	300	300	300

¹⁾ When the specified flow values are exceeded, the function of the return spring is no longer guaranteed if the pilot pressure fails.

²⁾ For symbol V, the pilot control valve is not required for flows >160 l/min.

3-spool position valves – $q_{V \max}$ in l/min

Symbol	Operating pressure p_{\max} in bar				
	70	140	210	280	350
X external – spring-centered					
E, H, J, L, M, Q, U, W, R	300	300	300	300	300
F, P	300	250	180	170	150
G, T	300	300	240	210	190
S	300	300	300	250	220
V	300	250	210	200	180
X external – pressure-centered (at minimum pilot pressure 16 bar)					
all symbols ²⁾	300	300	300	300	300

 For important notices, see page 27.

Characteristic curves: NG25 ("W.H 22")
(measured with HLP46, $\vartheta_{oil} = 40 \pm 5 \text{ }^\circ\text{C}$)

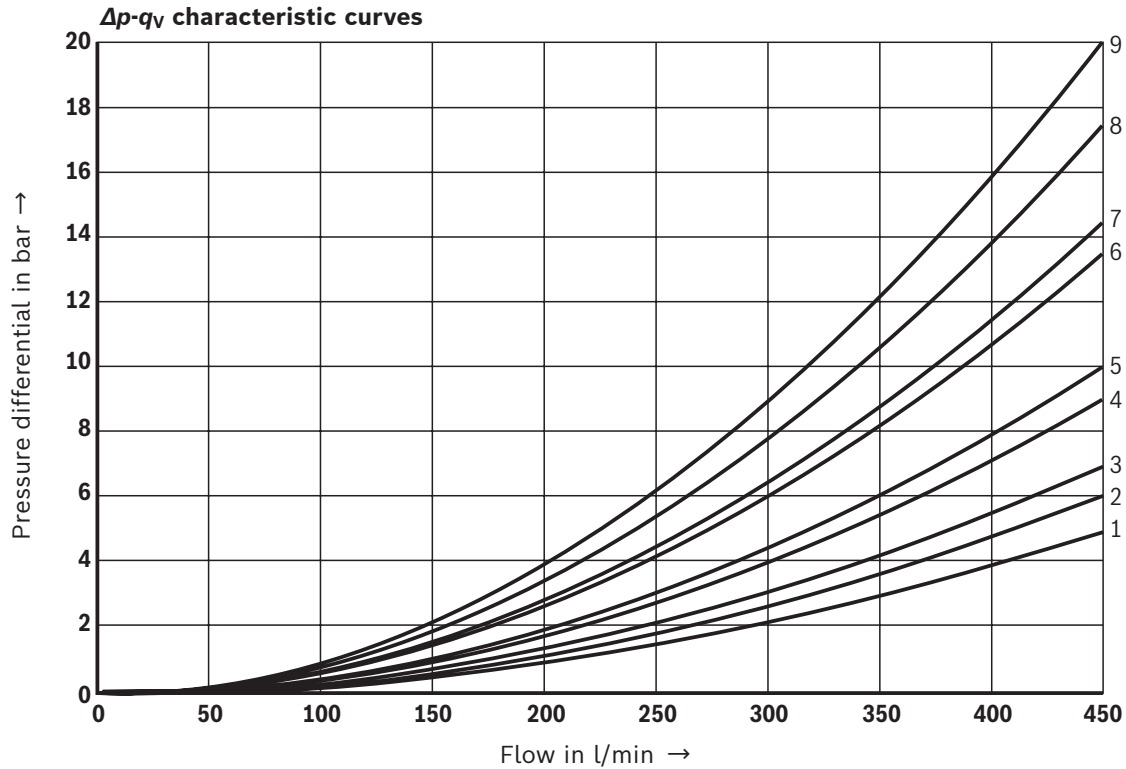

Symbol	Spool position				
	P - A	P - B	A - T	B - T	B - A
E, D	2	2	3	5	-
J, Q, K	2	2	4	6	-
M, W	1	1	3	5	-
H, V, C, Z	1	1	4	6	-
F	1	2	4	5	-
G	3	4	5	6	-
R	1	2	2	-	-
L	2	2	4	5	-
U	2	2	2	6	-
P	2	2	2	7	-
T	4	4	5	6	-

Symbol	Zero position		
	A - T	B - T	P - T
F	2	-	4
G, T	-	-	9
H	-	-	3
L	7	-	-
U	-	6	-
J	8	8	-
P	-	4	6
V, Z	-	-	8

Performance limits: NG25 ("W.H 22")
(measured with HLP46, $\vartheta_{oil} = 40 \pm 5 \text{ }^\circ\text{C}$)

2-spool position valves – $q_{V \max}$ in l/min

Symbol	Operating pressure p_{\max} in bar				
	70	140	210	280	350
X external – spring end position in the main valve (at $p_{St \min} = 11 \text{ bar} / 14 \text{ bar}$)					
C, D, K, Y, Z	450	450	450	450	450
X external – spring end position in the main valve ¹⁾					
C	450	450	320	250	200
D, Y	450	450	450	400	320
K	450	215	150	120	100
Z	350	300	290	260	160
X external – hydraulic end position in the main valve					
HC, HD, HK, HZ, HY	450	450	450	450	450
HC./O..., HD./O..., HK./O..., HZ./O...	450	450	450	450	450
HC./OF..., HD./OF..., HK./OF..., HZ./OF...	450	450	450	450	450

¹⁾ When the specified flow values are exceeded, the function of the return spring is no longer guaranteed if the pilot pressure fails.

3-spool position valves – $q_{V \max}$ in l/min

Symbol	Operating pressure p_{\max} in bar				
	70	140	210	280	350
X external – spring-centered					
E, J, L, M, Q, U, W, R	450	450	450	450	450
H	450	450	300	260	230
G	400	350	250	200	180
F	450	270	175	130	110
V	450	300	240	220	160
T	400	300	240	200	160
P	450	270	180	170	110

 For important notices, see page 27.

Characteristic curves: NG25 ("W.H 25")
(measured with HLP46, $\vartheta_{oil} = 40 \pm 5 \text{ }^\circ\text{C}$)

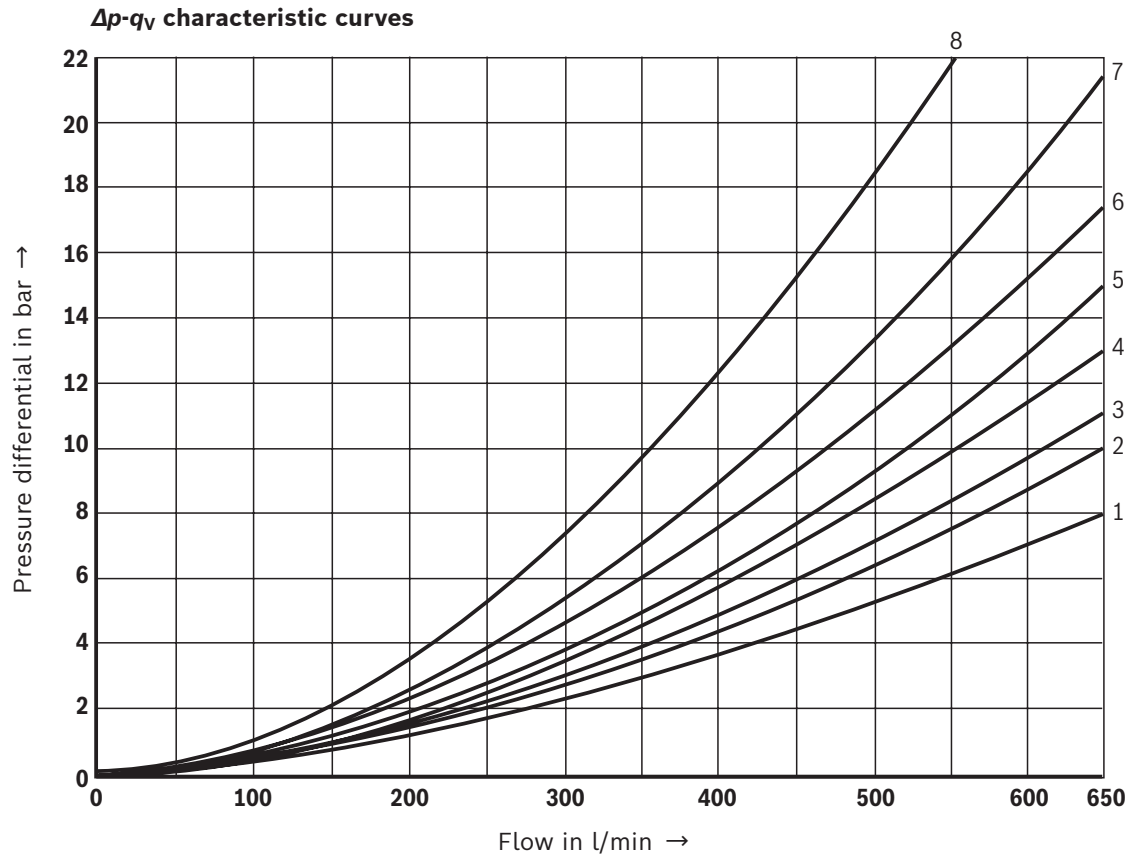

Symbol	Spool position				Zero position		
	P - A	P - B	A - T ¹⁾	B - T ¹⁾	A - T	B - T	P - T
E, Y, D	1	1	3	4			
F	1	1	2	4	2	-	5
G, T	1	1	2	5	-	-	7
H	1	1	2	5	2	2	4
C	1	1	2	5			
J	1	1	2	5	6	5	-
K	1	1	2	5			
L	1	1	2	4	5	-	-
M	1	1	3	4			
P	1	1	3	5	-	3	5
Q	1	1	2	3			
R	1	1	3	-			
U	1	1	2	5	-	5	-
V	1	1	2	5	8	7	-
Z	1	1	2	5			
W	1	1	3	4			

8 Symbol R, spool position B - A

Performance limits: NG25 ("W.H 25")
(measured with HLP46, $\vartheta_{oil} = 40 \pm 5 \text{ }^\circ\text{C}$)

2-spool position valves – $q_{V \max}$ in l/min

Symbol	Operating pressure p_{\max} in bar				
	70	140	210	280	350
X external – spring end position in the main valve (at $p_{St \min} = 13 \text{ bar}$)					
C, D, K, Y, Z	700	700	700	700	650
X external – spring end position in the main valve ¹⁾					
C	700	700	700	700	650
D, Y	700	650	400	350	300
K	700	650	420	370	320
Z	700	700	650	480	400
X external – hydraulic end position in the main valve					
HC, HD, HK, HZ, HY	700	700	700	700	700
HC./O..., HD./O..., HK./O..., HZ./O...	700	700	700	700	700
HC./OF..., HD./ OF..., HK./OF..., HZ./OF...	700	700	700	700	700

¹⁾ When the specified flow values are exceeded, the function of the return spring is no longer guaranteed if the pilot pressure fails.

3-spool position valves – $q_{V \max}$ in l/min

Symbol	Operating pressure p_{\max} in bar				
	70	140	210	280	350
X external – spring-centered					
E, L, M, Q, U, W	700	700	700	700	650
G, T	400	400	400	400	400
F	650	550	430	330	300
H	700	650	550	400	360
J	700	700	650	600	520
P	650	550	430	330	300
V	650	550	400	350	310
R	700	700	700	650	580
X external – pressure-centered (at minimum pilot pressure 18 bar)					
E, F, H, J, L, M, P, Q, R, U, V, W	700	700	700	700	650
G, T	400	400	400	400	400
X external – pressure-centered (with pilot pressure > 30 bar)					
G, T	700	700	700	700	650

 For important notices, see page 27.

Characteristic curves: NG32
 (measured with HLP46, $\vartheta_{oil} = 40 \pm 5 \text{ }^\circ\text{C}$)

Δp - q_V -characteristic curves – Symbol **E, R** and **W**

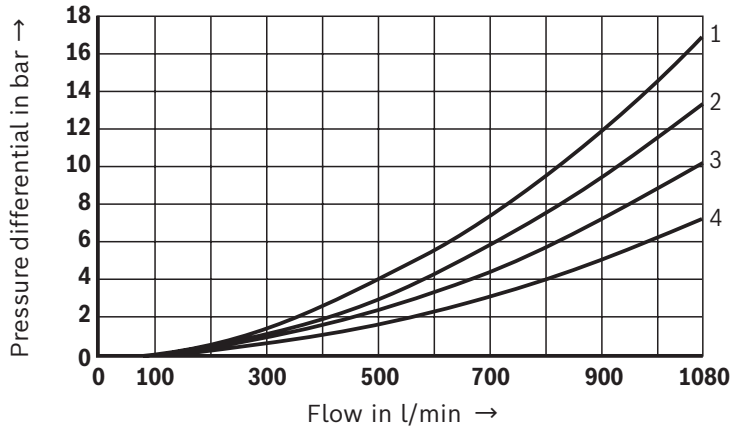

Symbol	Spool position				
	P - A	P - B	A - T	B - T	B - A
E	4	4	3	2	-
R	4	4	3	-	1
W	4	4	3	2	-

Δp - q_V characteristic curves – Symbol **G** and **T**

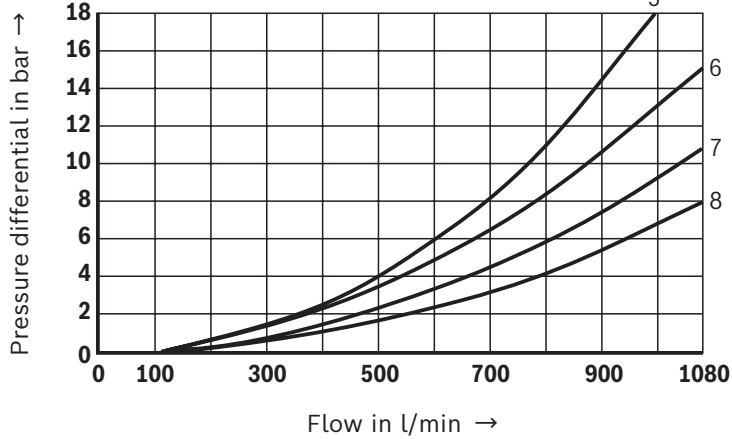

Symbol	Spool position				
	P - A	P - B	A - T	B - T	P - T
G	7	8	7	5	6
T	7	8	7	5	6

Performance limits: NG32
(measured with HLP46, $\vartheta_{oil} = 40 \pm 5 \text{ }^\circ\text{C}$)

2-spool position valves – $q_{V \max}$ in l/min

Symbol	Operating pressure p_{\max} in bar				
	70	140	210	280	350
X external – spring end position in the main valve (at $p_{St \min} = 10 \text{ bar}$)					
C, D, K, Y, Z	1100	1040	860	750	680
X external – spring end position in the main valve ¹⁾					
C	1100	1040	860	800	700
D, Y	1100	1040	540	480	420
K	1100	1040	860	500	450
Z	1100	1040	860	700	650
X external – hydraulic end position in the main valve					
HC, HD, HK, HZ, HY	1100	1040	860	750	680

¹⁾ When the specified flow values are exceeded, the function of the return spring is no longer guaranteed if the pilot pressure fails.

3-spool position valves – $q_{V \max}$ in l/min

Symbol	Operating pressure p_{\max} in bar				
	70	140	210	280	350
X external – spring-centered					
E, J, L, M, Q, R, U, W	1100	1040	860	750	680
G, T, H, F, P	900	900	800	650	450
V	1100	1000	680	500	450
X external – pressure-centered (at minimum pilot pressure 8.5 bar)					
all symbols	1100	1040	860	750	680
X external – pressure-centered (at minimum pilot pressure 15 bar)					
all symbols	1100	1100	1100	1100	1100

 **Important notices** (applies to all sizes):

The specified performance limits apply to the use with two directions of flow (e.g. from P to A and simultaneous return flow from B to T at a ratio of 1:1).

Due to the flow forces acting within the valves, the admissible switching power limit may be considerably lower with only one direction of flow (e.g. from P to A

while port B is blocked, with flow in the same or in different directions).

In such cases of use, please consult us.

The performance limits were determined when the solenoids were at operating temperature, at 10% undervoltage and without tank preloading.

Dimensions: NG10
(dimensions in mm)

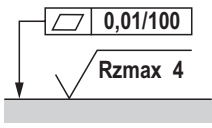
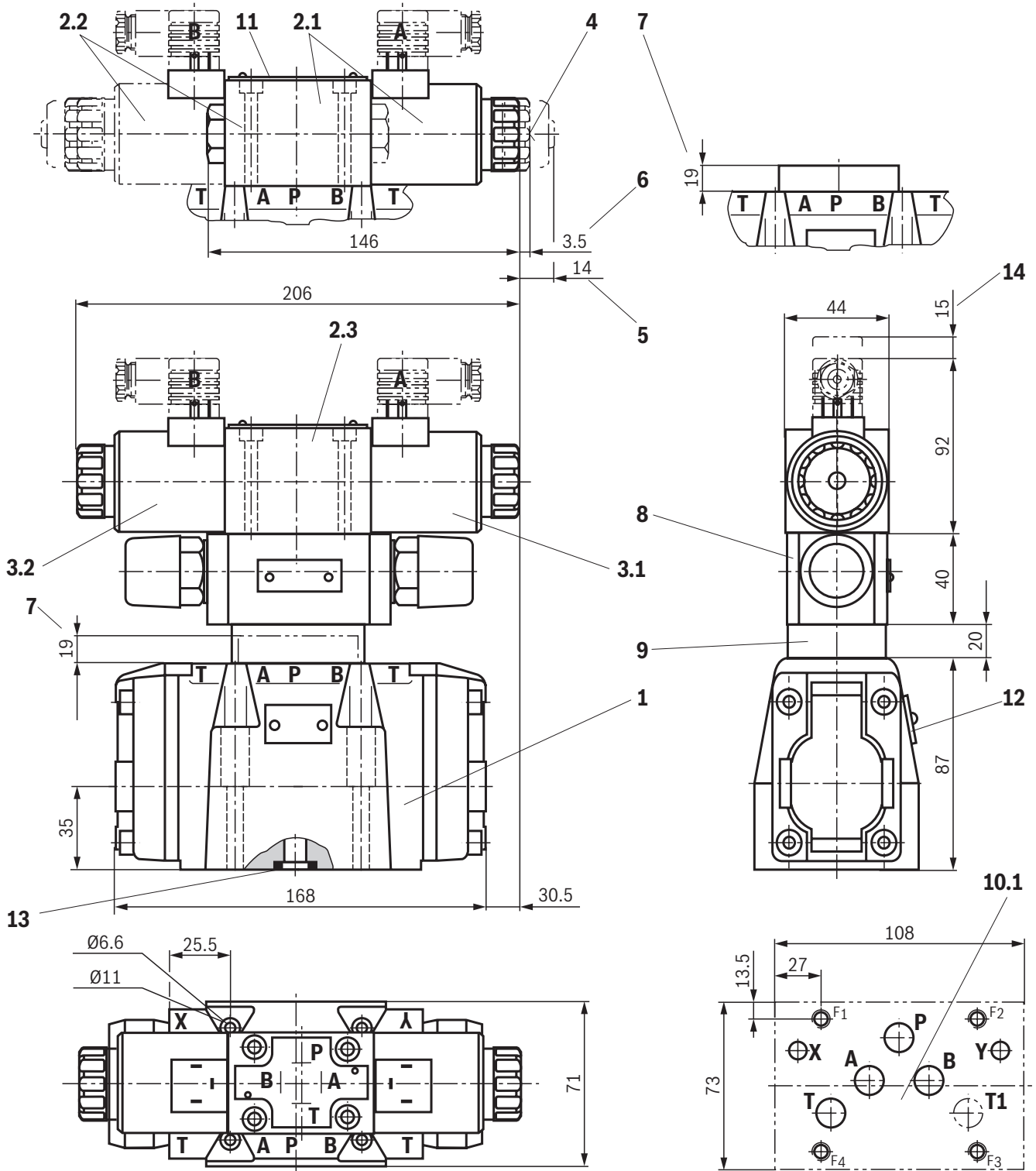

Required surface quality of the valve contact surface

Notice:

The dimensions are nominal dimensions which are subject to tolerances.

For item explanations and subplates, see page 33.
Valve mounting screws, see page 34.

Dimensions: NG16
(dimensions in mm)

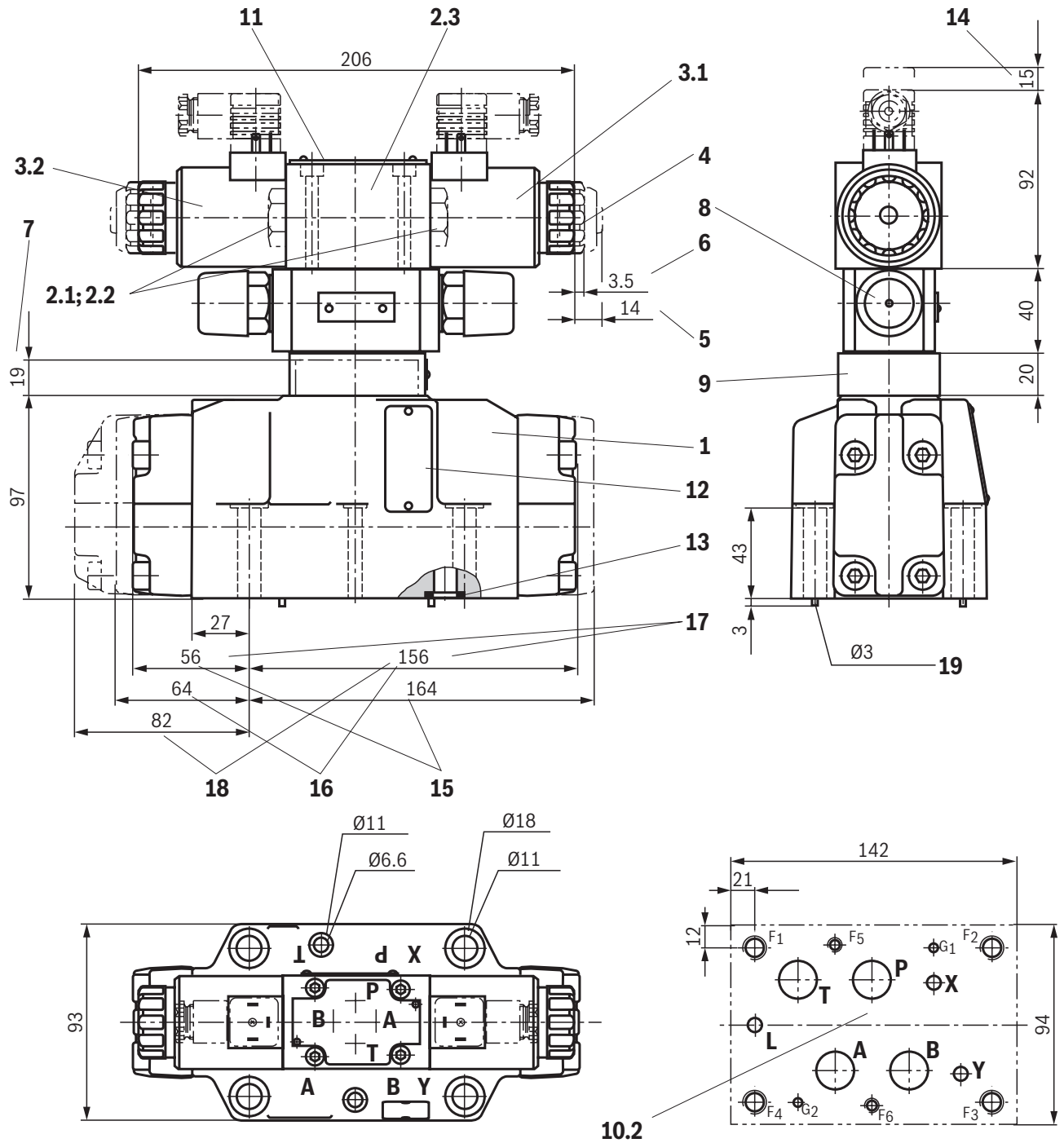

For item explanations and subplates, see page 33.
Valve mounting screws, see page 34.

Notice:
The dimensions are nominal dimensions which are subject to tolerances.

0,01/100
Rzmax 4
Required surface quality of the valve contact surface

Dimensions: NG25 ("W.H 22")
(dimensions in mm)

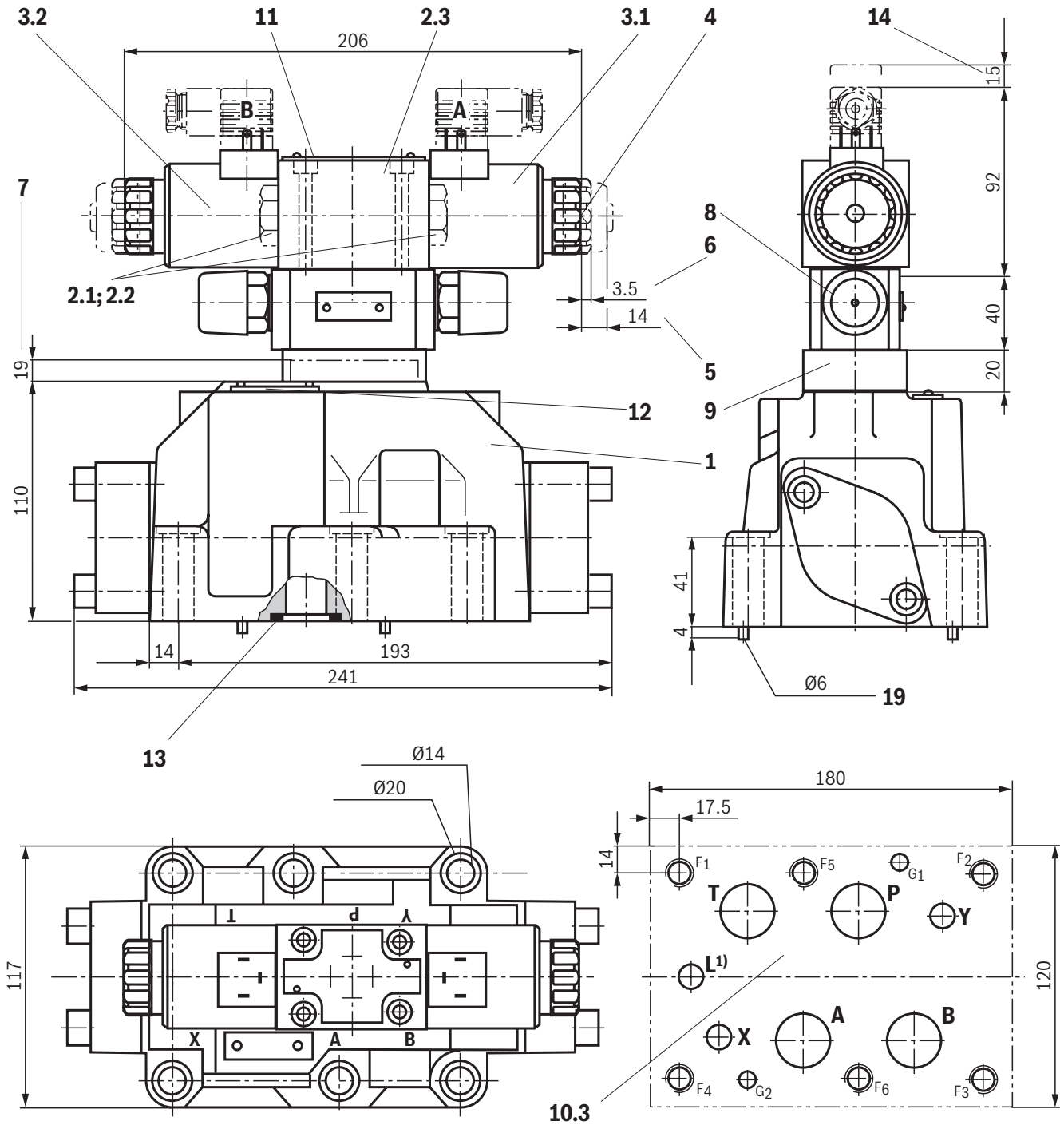

1) Port L only for valves with pressure-centered zero position

For item explanations and subplates, see page 33.
Valve mounting screws, see page 34.

Notice:
The dimensions are nominal dimensions which are subject to tolerances.

$0,01/100$
 $Rz_{max} 4$
Required surface quality of the valve contact surface

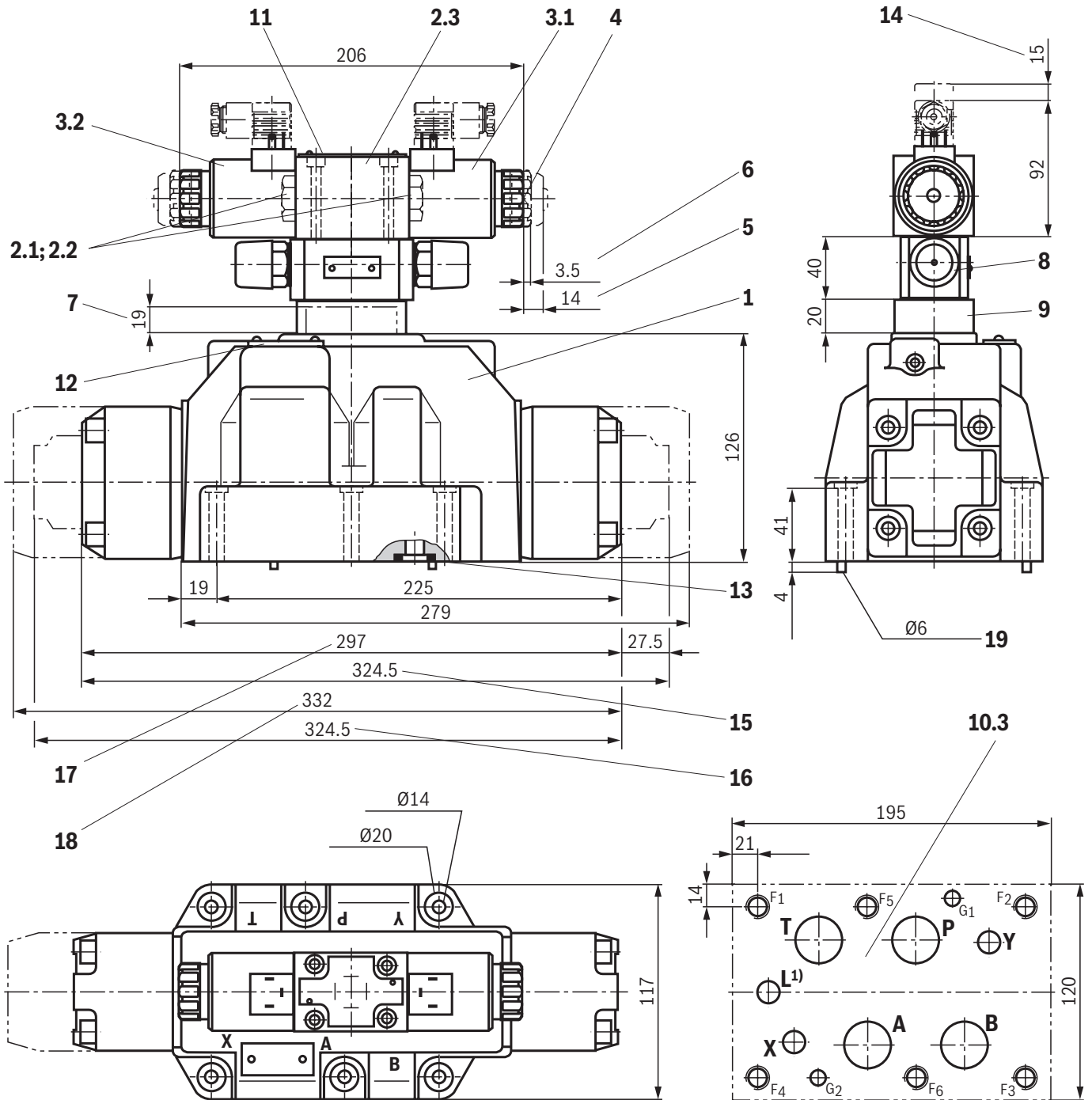
Dimensions: NG25 ("W.H 25")
 (dimensions in mm)

1) Port L only for valves with pressure-centered zero position

For item explanations and subplates, see page 33.

Valve mounting screws, see page 34.

Notice:

The dimensions are nominal dimensions which are subject to tolerances.

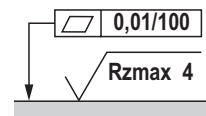

Required surface quality of the valve contact surface

Dimensions: NG32
(dimensions in mm)

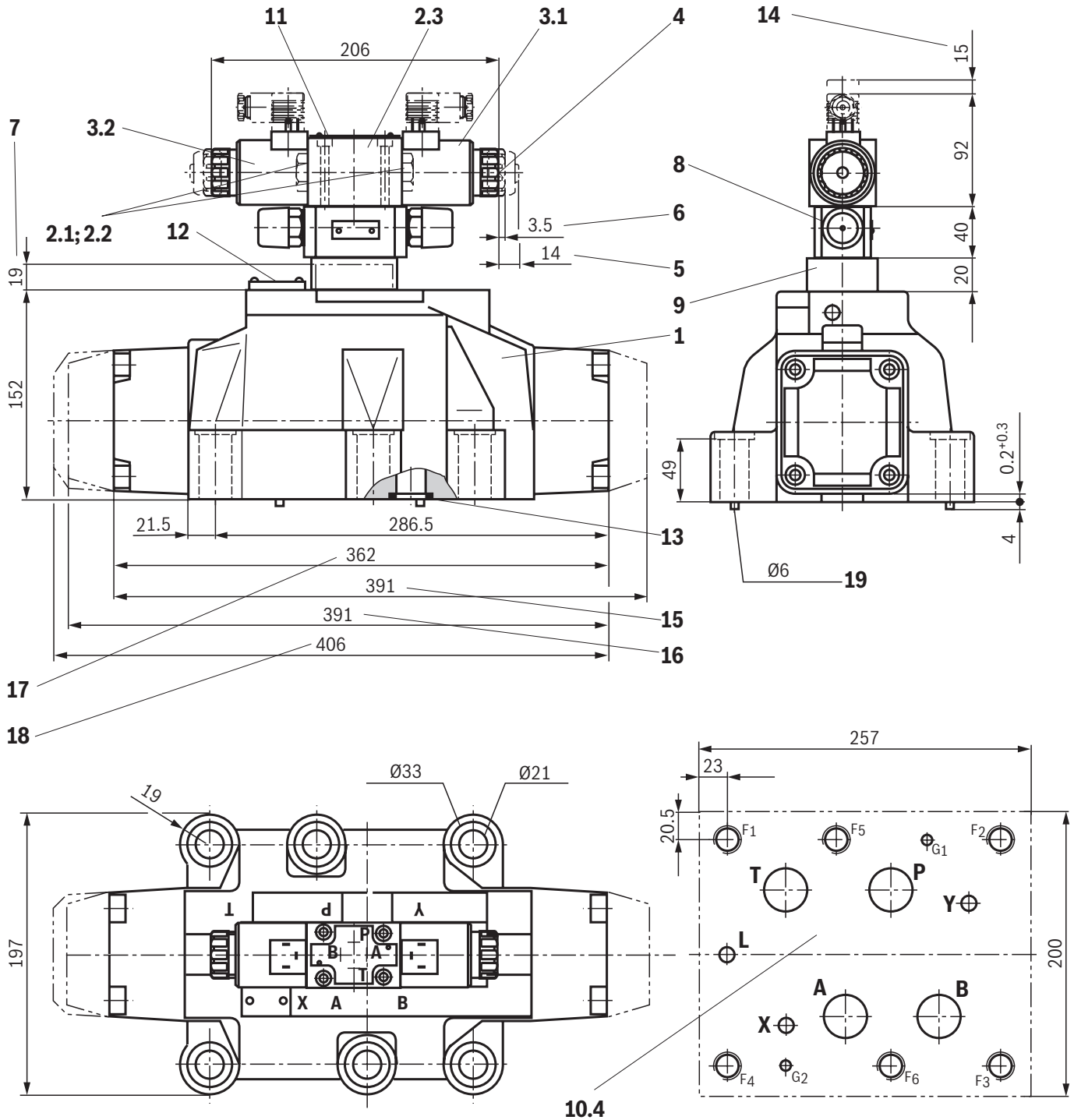

For item explanations and subplates, see page 33.
Valve mounting screws, see page 34.

Notice:
The dimensions are nominal dimensions which are subject to tolerances.

\square 0,01/100
 ∇ Rzmax 4
Required surface quality of the valve contact surface

Dimensions

- 1 Main valve
- 2 Pilot control valve type 4WE 6 ... (data sheet 23178):
 - 2.1 ▶ Pilot control valve type 4WE 6 D... (1 solenoid) for main valves with Symbols C, D, K, Z
Symbols HC, HD, HK, HZ
 - ▶ Pilot control valve type 4WE 6 JA... (1 solenoid "a") for main valves with symbols EA, FA, etc.,
Spring return
 - ▶ Pilot control valve type 4WE 6 MA... (1 solenoid "a") for main valves with symbols HEA, HFA, etc.,
hydraulic control spool return
 - 2.2 ▶ Pilot control valve type 4WE 6 Y... (1 solenoid "a") for main valves with Symbol Y
Symbol HY
 - ▶ Pilot control valve type 4WE 6 JB... (1 solenoid "b") for main valves with symbols EB, FB, etc.,
Spring return
 - ▶ Pilot control valve type 4WE 6 MB... (1 solenoid "b") for main valves with symbols HEB, HFB, etc., hydraulic control spool return
 - 2.3 ▶ Pilot control valve type 4WE 6 J... (2 solenoids) for main valves with 3 spool positions, spring-centered
 - ▶ Pilot control valve type 4WE6M... (2 solenoids) for main valves with 3 spool positions,
pressure-centered
- 3.1 Solenoid "a"
- 3.2 Solenoid "b"
- 4 Manual override, "N", optional
 - ▶ Actuation of the manual override is only possible up to a tank pressure of approx. 50 bar. Avoid damage to the bore of the manual override. (Special tool for the operation, separate order, material no. **R900024943**). When the manual override is blocked, the operation of the solenoid must be prevented.
 - ▶ Simultaneous actuation of the solenoids must be prevented.
- 5 Solenoid **without** manual override
- 6 Solenoid **with** manual override
- 7 Height of the diversion plate with hydraulic actuation (type WH...)
- 8 Switching time adjustment (wrench size 6), optional
- 9 Pressure reducing valve, optional
- 10.1 Machined valve contact surface; porting pattern according to ISO 4401-05-05-0-05
- 10.2 Machined valve contact surface; porting pattern according to ISO 4401-07-07-0-05
- 10.3 Machined valve contact surface; porting pattern according to ISO 4401-08-08-0-05
- 10.4 Machined valve contact surface; porting pattern according to ISO 4401-10-09-0-05
- 11 Name plate pilot control valve
- 12 Name plate complete valve
- 13 Seal rings
- 14 Space required for removing the mating connector
- 15 2-spool position valves with spring end position in the main valve (symbols A, C, D, K, Z)
- 16 2-spool position valves with spring end position in the main valve (symbols B, Y)
- 17 3-spool position valves, spring-centered;
2-spool position valves with hydraulic end position in the main valve
- 18 3-spool position valves, pressure-centered
- 19 Locking pin

Subplates (separate order) with porting pattern according to ISO 4401, see data sheet 45100.

Valve mounting screws, see page 34.

Dimensions

Valve mounting screws (separate order)

Size	Quantity	Hexagon socket head cap screws	Material number
10	4	ISO 4762 - M6 x 45 - 10.9-CM-Fe-ZnNi-5-Cn-T0-H-B Friction coefficient $\mu_{\text{total}} = 0.09 \dots 0.14$; tightening torque $M_A = 12.5 \text{ Nm} \pm 10\%$	R913043777
	or		
	4	1/4-20 UNC x 1 3/4" ASTM-A574	Not included in the Rexroth delivery range
16	4	ISO 4762 - M10 x 60 - 10.9-fZn/nc/480h/C Friction coefficient $\mu_{\text{total}} = 0.09 \dots 0.14$; tightening torque $M_A = 58 \text{ Nm} \pm 10\%$	R913014770
	2	ISO 4762 - M6 x 60 - 10.9-CM-Fe-ZnNi-5-Cn-T0-H-B Friction coefficient $\mu_{\text{total}} = 0.09 \dots 0.14$; tightening torque $M_A = 12.5 \text{ Nm} \pm 10\%$	R913043410
	or		
	4	Hexagon socket head cap screws UNC 3/8-16 UNC x 2 1/4" - ASTM-A574	Not included in the Rexroth delivery range
2	Hexagon socket head cap screws UNC 1/4-20 UNC x 2 1/4" - ASTM-A574		
25	6	ISO 4762 - M12 x 60 - 10.9-fZn/nc/480h/C Friction coefficient $\mu_{\text{total}} = 0.09 \dots 0.14$; Tightening torque $M_A = 100 \text{ Nm} \pm 10\%$	R913015613
	or		
	6	UNC 1/2-13 UNC x 2 1/2" ASTM-A574	Not included in the Rexroth delivery range
32	6	ISO 4762 - M20 x 80 - 10.9-fZn/nc/480h/C Friction coefficient $\mu_{\text{total}} = 0.09 \dots 0.14$; tightening torque $M_A = 340 \text{ Nm} \pm 10\%$	R913008472
	or		
	6	UNC 3/4-10 UNC x 3 1/4" - ASTM-A574	Not included in the Rexroth delivery range

Stroke setting, mounting options (dimensions in mm)

The stroke of the control spool is limited by the stroke setting (1). The control spool stroke is shortened by loosening the lock nut (2) and clockwise rotation of the adjustment spindle (3). The control chamber (4) must be depressurized for this.

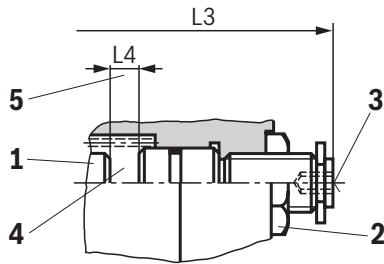

NG	L4
10	6.5
16	10
25 ("W.H 22")	9.5
25 ("W.H 25")	12.5
32	15

More dimensions
see below and
page 36.

5 Adjustment range

- ▶ NG10:
1 rotation = 1 mm adjustment travel
- ▶ NG16 and 32:
1 rotation = 1.5 mm adjustment travel

Stroke limitation on side A

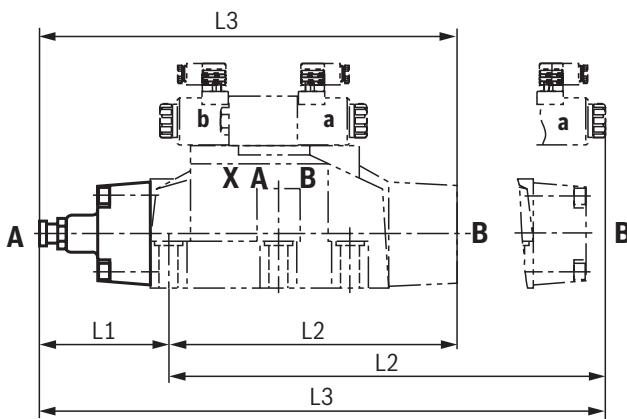

Stroke limitation on side B

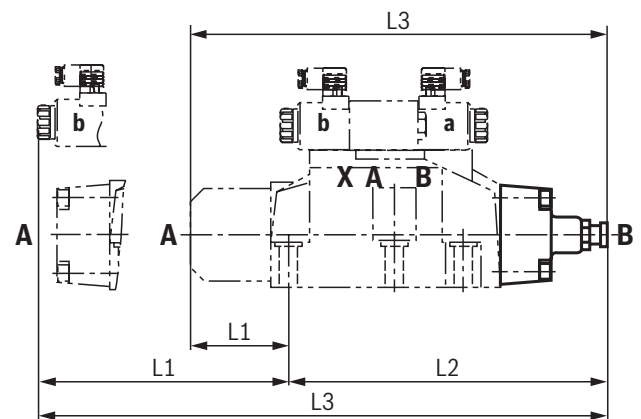

3-spool position valve ¹⁾

			spring-centered			pressure-centered		
			L1	L2	L3	L1	L2	L3
Stroke setting on valve side A and B	10	10	90	144	234			
		16	100	200	300			
		25 ²⁾	96	241	337			
		25 ³⁾	123	276	399			
		32	133	344	477			
Stroke setting on valve side A	11	10	90	106	196			
		16	100	156	256			
		25 ²⁾	96	193	289			
		25 ³⁾	123	225	348			
		32	133	287	420			
Stroke setting on valve side B	12	10	52	144	196	–	–	–
		16	56	200	256	81	200	281
		25 ²⁾	48	241	289	–	–	–
		25 ³⁾	72	276	348	107	276	283
		32	76	344	420	120	344	464

¹⁾ With symbol A only version "11", with symbol B only version "12" possible.

Stroke setting, mounting options

(dimensions in mm)

2-spool position valve

			Spring end position						Hydraulic end position		
			A, C, D, K, Z			B, Y			HC, HD, HK, HZ, HY		
			L1	L2	L3	L1	L2	L3	L1	L2	L3
Stroke setting on valve side A and B	10	10	90	144	234	90	144	234	90	144	234
		16	–	–	–	–	–	–	100	200	300
		25 ²⁾	96	241	337	96	241	337	96	241	337
		25 ³⁾	–	–	–	–	–	–	123	276	399
		32	–	–	–	–	–	–	133	344	477
Stroke setting on valve side A	11	10	90	106	196	90	106	196	90	106	196
		16	100	180	280	–	–	–	100	156	256
		25 ²⁾	96	193	289	96	193	289	96	193	289
		25 ³⁾	123	253	376	–	–	–	123	225	348
		32	133	316	449	–	–	–	133	287	420
Stroke setting on valve side B	12	10	52	144	196	52	144	196	52	144	196
		16	–	–	–	80	200	280	56	200	256
		25 ²⁾	48	241	289	48	241	289	48	241	289
		25 ³⁾	–	–	–	100	276	376	72	276	348
		32	–	–	–	105	344	449	76	344	420

2) Version "W.H 22"

3) Version "W.H 25"



Notice:

The dimensions are nominal dimensions which are subject to tolerances.

Switching time adjustment

The switching time of the main valve (1) is influenced by the use of a twin throttle check valve (2) (type Z2FS 6; data sheet 27506).

Modification of supply (3) to discharge control (4):

Remove the pilot control valve (5) – The plate (6) to accept the seal rings stays in place – Turn the switching time adjustment (2) around its longitudinal axis and put it back, install the pilot control valve (5).

Notice:

The modification may only be performed by authorized specialists or at the factory.

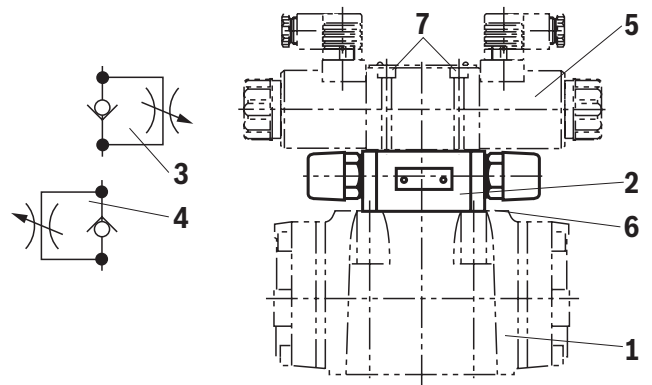

Type .WEH 10 ..4X/...S
Type .WEH 10 ..4X/...S2

Pressure reducing valve "D3"

The pressure reducing valve (8) has to be used at a pilot pressure above 250 bar (with "WEH 22 ...": 210 bar) and with version "H-".

The secondary pressure is kept at a constant level of 45 bar.

Notice:

- ▶ If a pressure reducing valve "D3" (8) is used, a "B10" throttle insert has to be installed in channel P of the pilot control valve.
- ▶ The modification may only be performed by authorized specialists or at the factory.

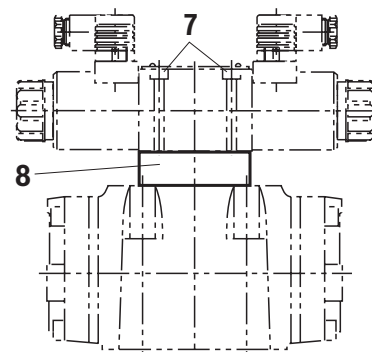

Type .WEH 10 ..4X/.../..D3

Preload valve (not for NG10)

In case of valves with depressurized circulation and internal pilot oil supply, the installation of the preload valve (9) in channel P of the main valve is required in order to build up the minimum pilot pressure.

The pressure differential of the preload valve is to be added to the pressure differential of the main valve (see characteristic curves) to result in one total value. The cracking pressure amounts to approx. 4.5 bar.

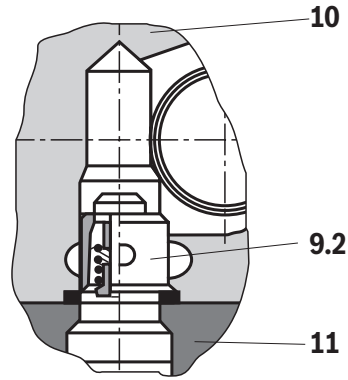
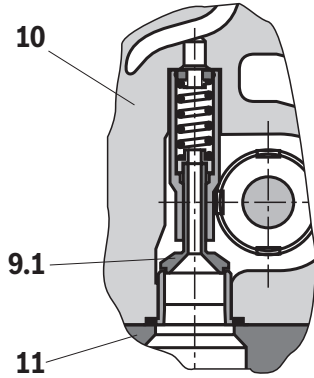

- 9.1 Preload valve
- 9.2 Preload valve
- 10 Main valve
- 11 Subplate



Notice:

For series-production status, see ordering key on the name plate.

Size	Item 9.1	Item 9.2
16	R961009415 (from component series 72)	R961009417 (up to component series 71)
25 ("W.H 22")	R961009609	-
25 ("W.H 25")	R961009166 (from component series 68)	R961009416 (up to component series 67)
32	-	R961009610 (up to component series 63)

Δp - q_v characteristic curve (measured with HLP46, $\vartheta_{oil} = 40\text{ °C} \pm 5\text{ °C}$)

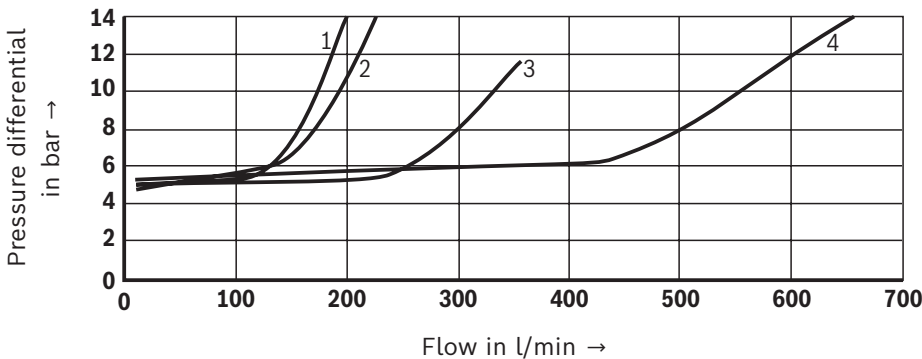

- 1 NG16
- 2 NG25 ("W.H 25")
- 3 NG25 ("W.H 22")
- 4 NG32

Project planning information

The stipulations of the Machinery Directive 2006/42/EC are to be adhered to.

Please also note data sheet 08012 with information on $MTTF_D$ values and shock and vibration loads.

Further information

- | | |
|--|--|
| ▶ Directional spool valve | Data sheet 23178 |
| ▶ Subplates | Data sheet 45100 |
| ▶ Inductive position switch and proximity sensors (contactless) | Data sheet 24830 |
| ▶ Hydraulic fluids on mineral oil basis | Data sheet 90220 |
| ▶ Environmentally compatible hydraulic fluids | Data sheet 90221 |
| ▶ Flame-resistant, water-free hydraulic fluids | Data sheet 90222 |
| ▶ Flame-resistant hydraulic fluids - containing water (HFAE, HFAS, HFB, HFC) | Data sheet 90223 |
| ▶ Reliability characteristics according to EN ISO 13849 | Data sheet 08012 |
| ▶ Hexagon socket head cap screw, metric/UNC | Data sheet 08936 |
| ▶ Hydraulic valves for industrial applications | Operating instructions 07600-B |
| ▶ General product information on hydraulic products | Data sheet 07008 |
| ▶ Assembly, commissioning and maintenance of industrial valves | Data sheet 07300 |
| ▶ Mating connectors and cable sets for valves and sensors | Data sheet 08006 |
| ▶ Directional spool and seat valves with electrical actuation and M12x1 plug-in connection | Data sheet 08010 |
| ▶ Use of non-electrical hydraulic components in an explosive environment (ATEX) | Data sheet 07011 |
| ▶ Selection of filters | www.boschrexroth.com/filter |
| ▶ Information on available spare parts | www.boschrexroth.com/spc |

Notes

Bosch Rexroth AG
Industrial Hydraulics
Zum Eisengießer 1
97816 Lohr am Main, Germany
Phone +49 (0) 93 52/40 30 20
my.support@boschrexroth.de
www.boschrexroth.de

© All rights reserved to Bosch Rexroth AG, also regarding any disposal, exploitation, reproduction, editing, distribution, as well as in the event of applications for industrial property rights.
The data specified above only serve to describe the product. No statements concerning a certain condition or suitability for a certain application can be derived from our information. The information given does not release the user from the obligation of own judgment and verification.
It must be remembered that our products are subject to a natural process of wear and aging.